

Hydrogeology

Ground Penetrating Radar (GPR)

Jakob Wilk

Institute of Earth and Environmental Science



Introduction

Where from where to?

- GPR is a geophysical measurement technique which can be applied to explore near-surface underground structures.
- The measurement principle is based on the transmittance (transmitting antenna) of high-frequency (~ 12.5 MHz – 2.5 GHz) electromagnetic pulses into the ground. Reflection or Refraction at inhomogeneities are received (receiving antenna).
- Travel time and amplitude give information about the structure and depth of the inhomogeneities.

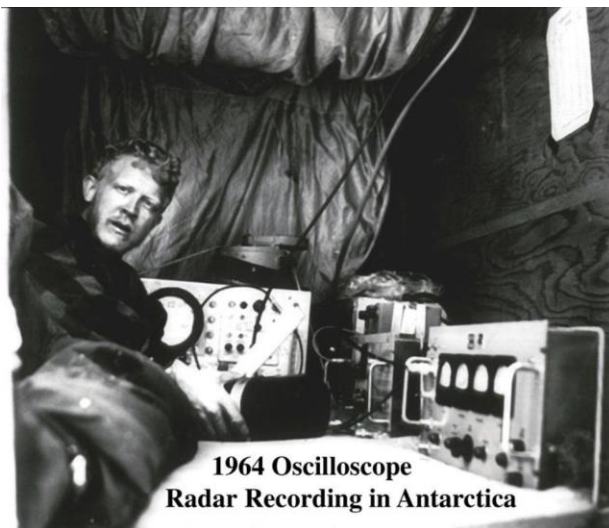

left: „radio sounding“ Skelton Glacier in 1964 (Sensors&Software) middle: dipole antenna layed out by Apollo 17 in 1972 (NASA) right: surveying the Canadian Arctic in 1975 (Annan et al. 1988)

Introduction

Where from where to?

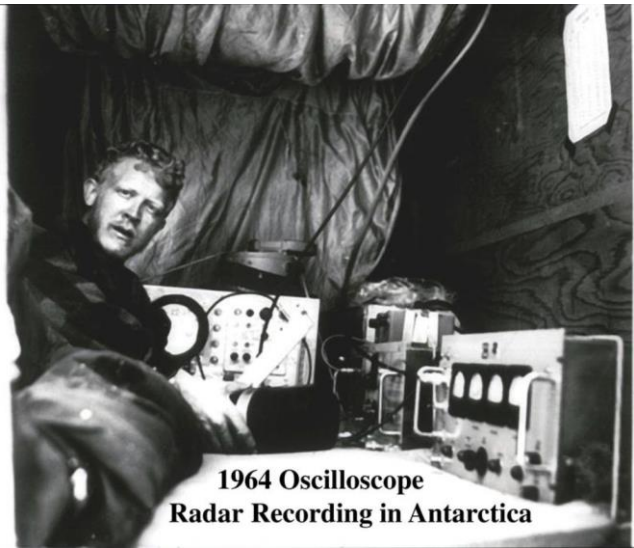

1964 Oscilloscope
Radar Recording in Antarctica

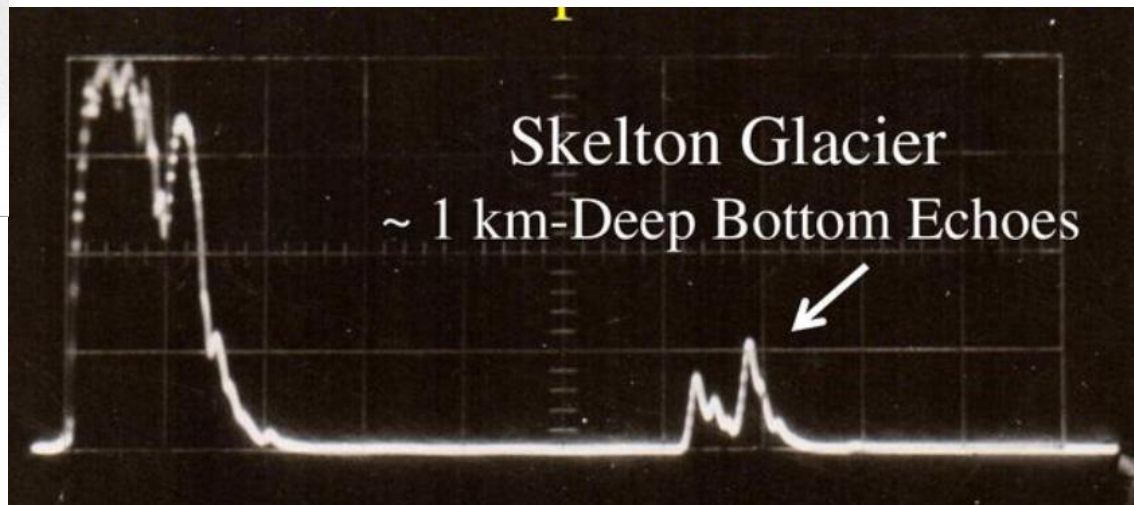
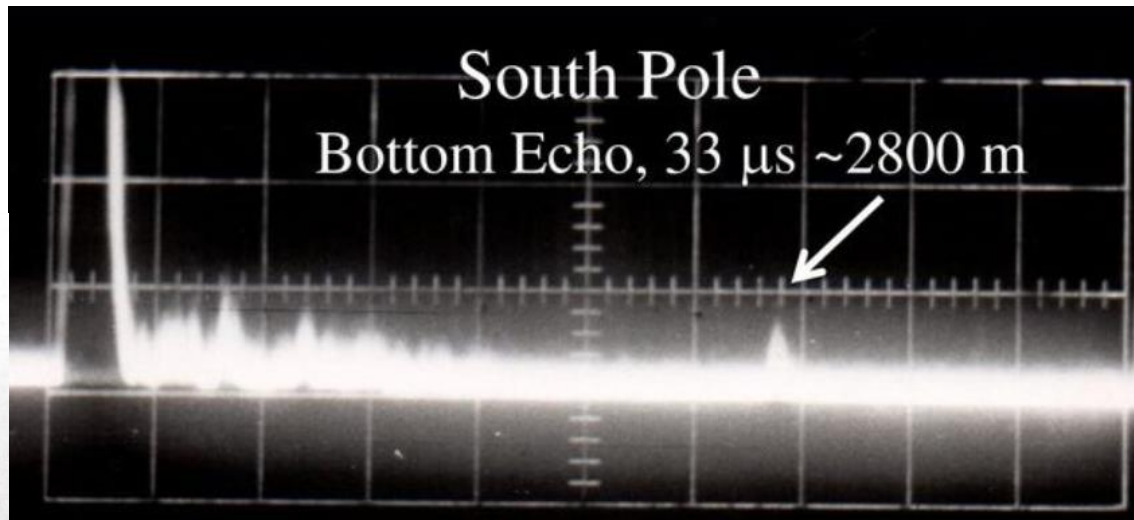

Introduction

Earth Sciences

Applications in other fields

Geological

- Detection of cavities and fissures
- Mapping of superficial deposits, subsidence, soil stratigraphy, fractures, etc.
- Mineral exploration and resource evaluation
- (Paleo-) Lake and riverbed mapping

Environmental

- Contaminant plume mapping
- Location of gas leaks
- Groundwater-level
- Mapping of pollutants within groundwater

Glaciological

- Ice thickness and snow stratigraphy

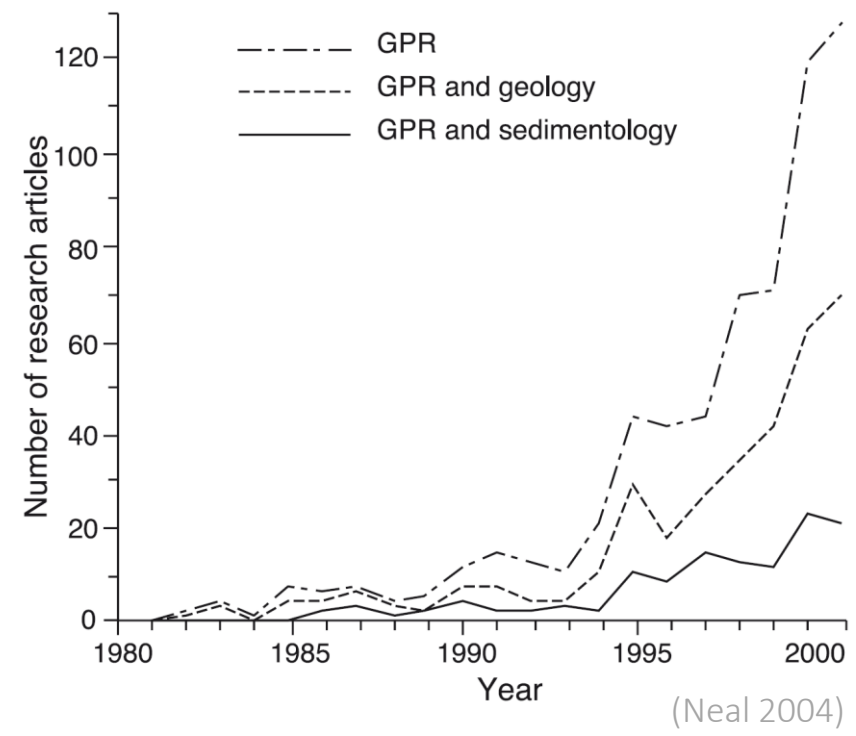

Fault mapping

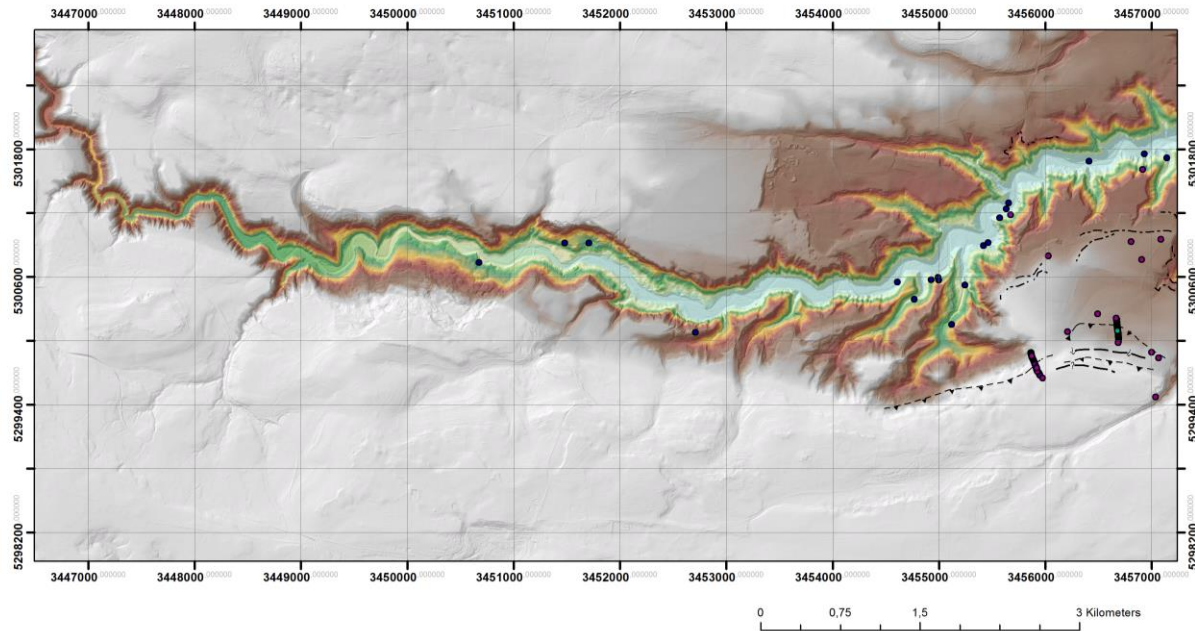

Introduction

Fault mapping

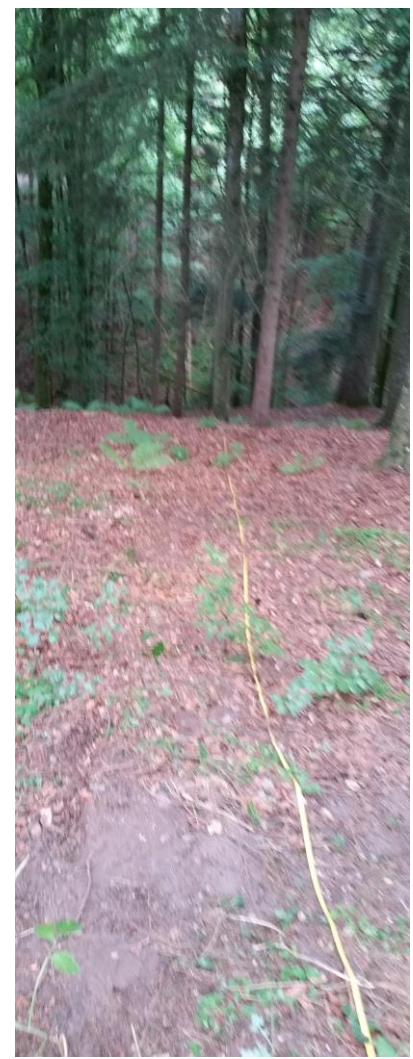
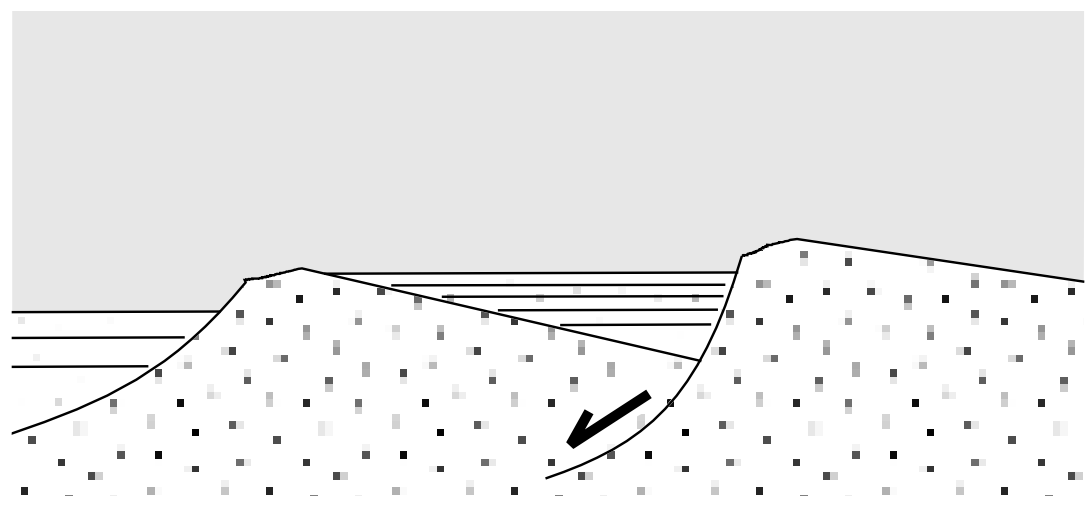
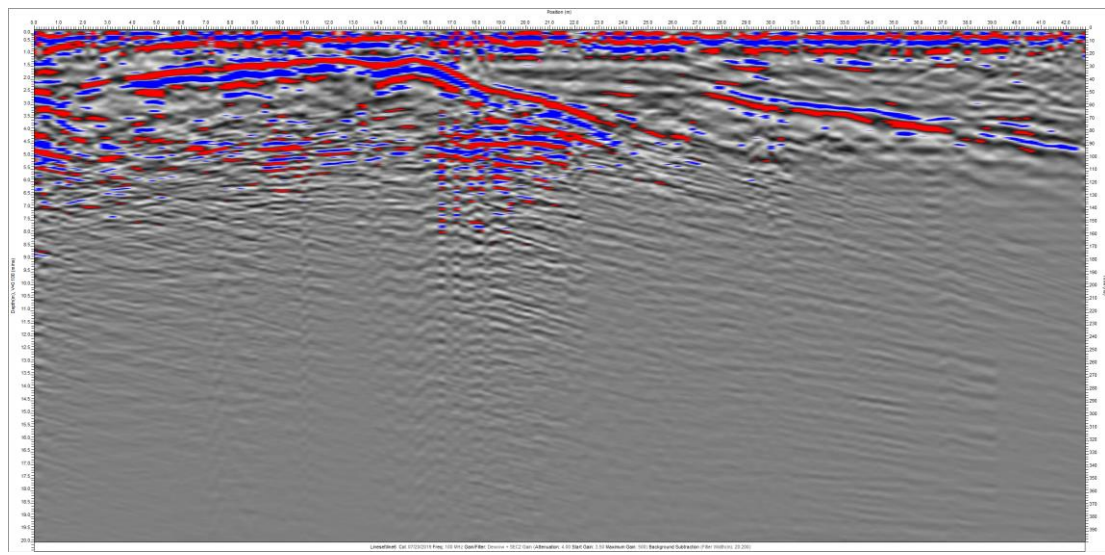

view NE - from upper to lower terrace

Introduction

Stratigraphic contacts

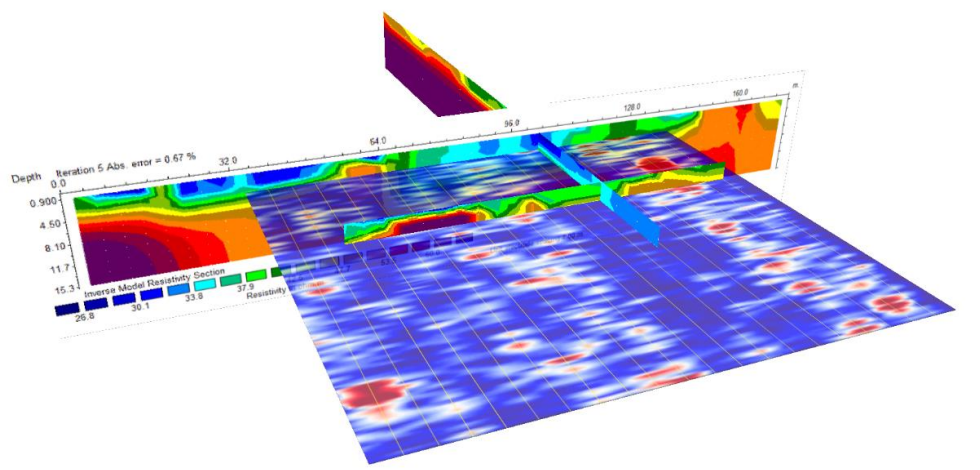

Introduction

Interferometric synthetic aperture radar - InSAR

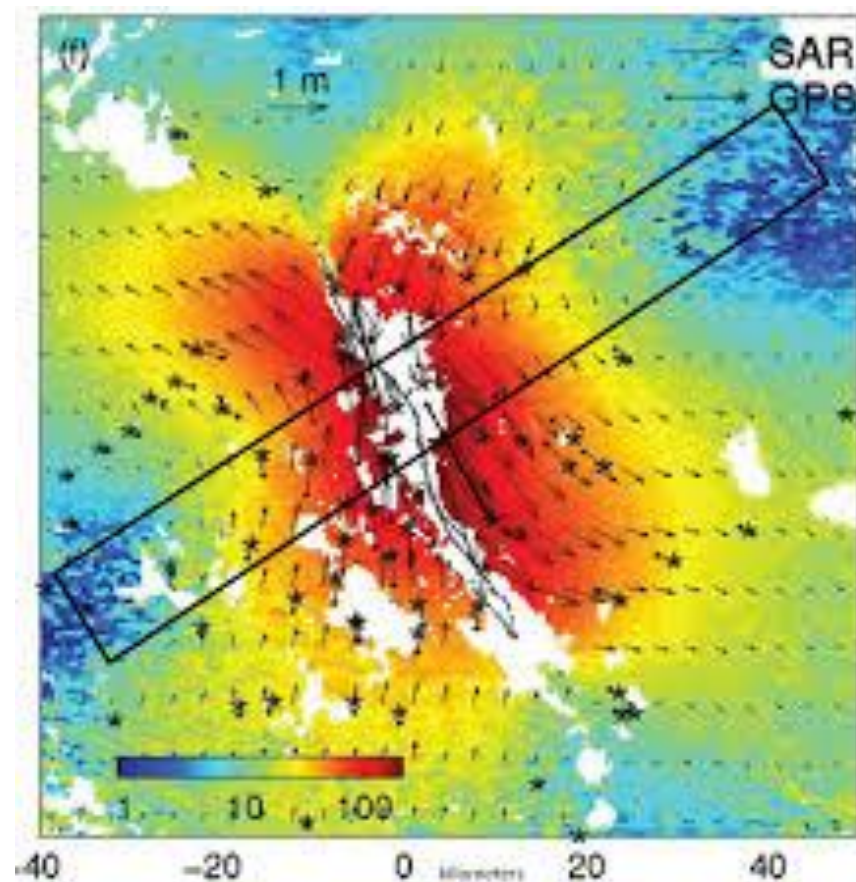
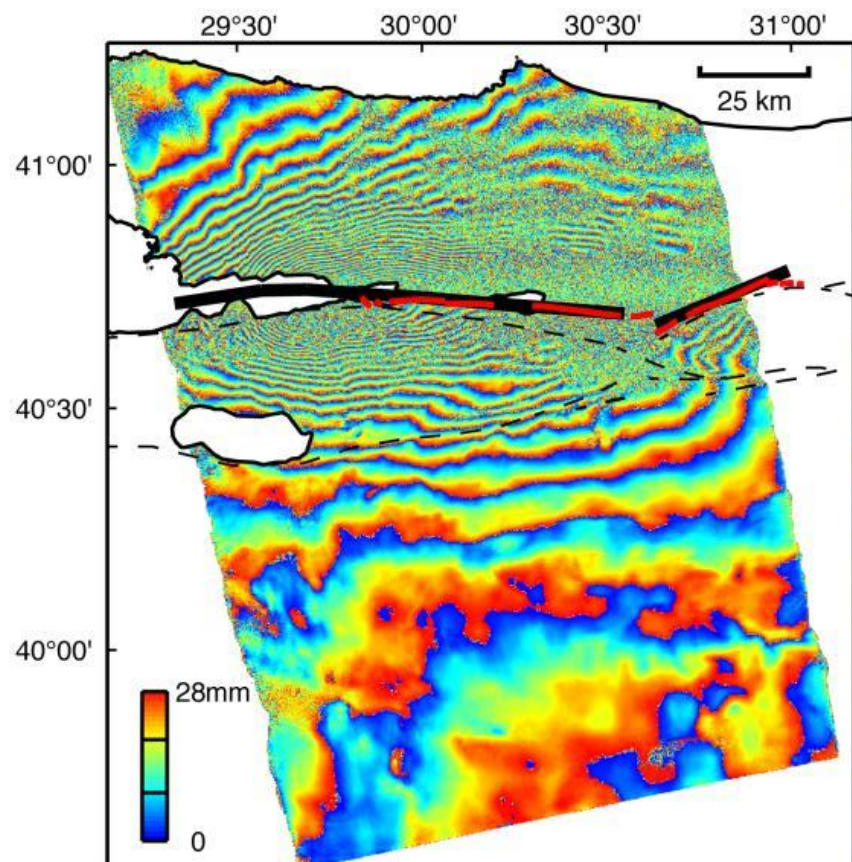

Interferogram produced using ERS-2 data from 13 August and 17 September 1999, spanning the 17 August Izmit (Turkey) earthquake. (NASA/JPL-Caltech)

Introduction

Combination of Remote sensing (InSAR) and field data



GPR profiling Antarctic ice shield
with courtesy by Drews (2021), Uni Tübingen

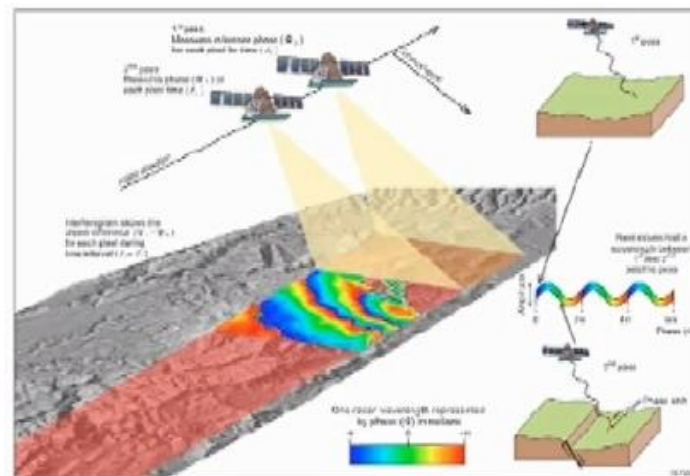

Künzer et al. (2019), DLR

Introduction

Combination of Remote sensing (InSAR) and field data



GPR interferometry Antarctic ice shield
with courtesy by Drews (2021), Uni Tübingen



Introduction

Shallow radar sounder - SHARAD

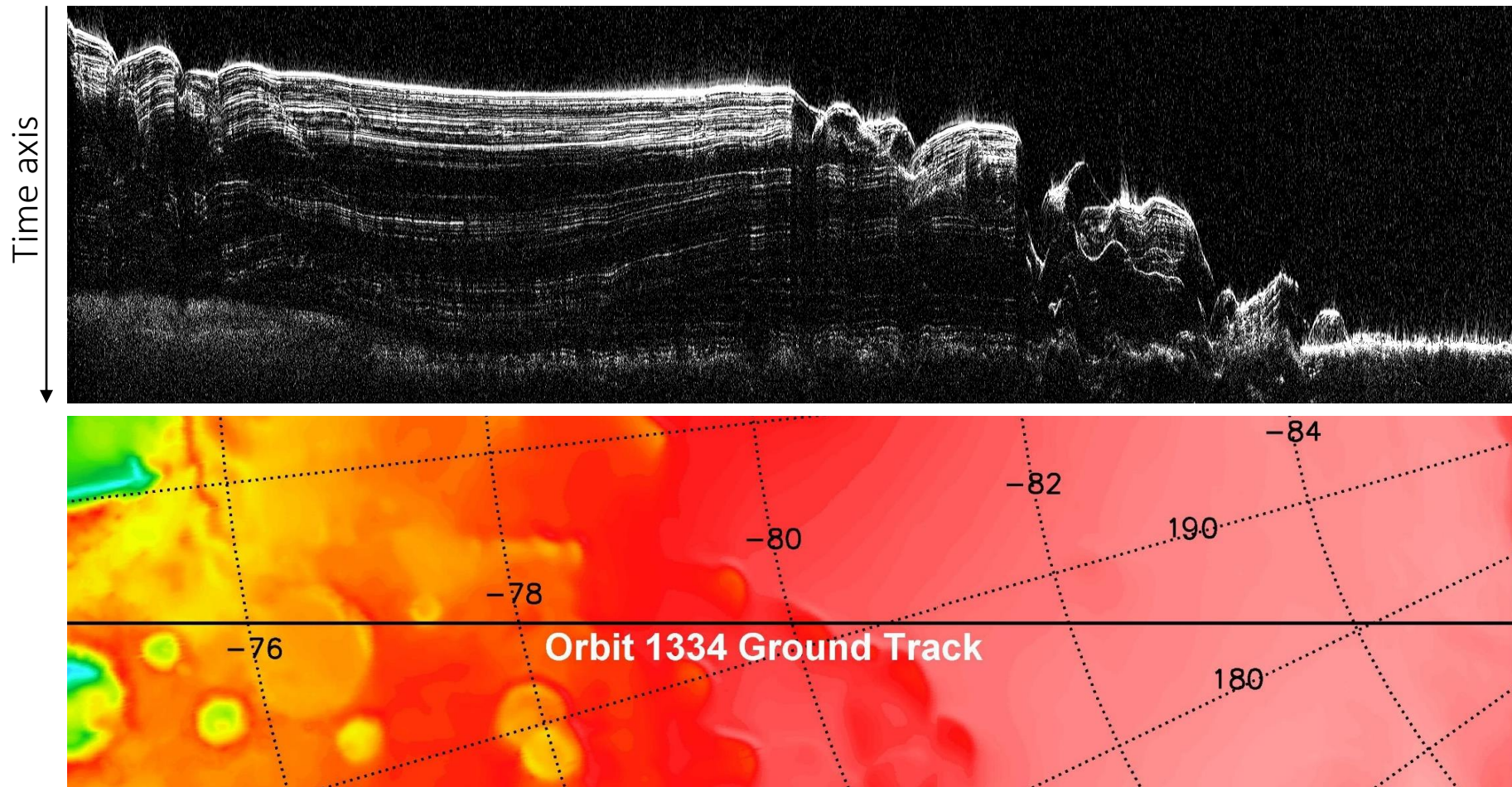

Radargram of north pole layered deposits. (ASI, Mars Reconnaissance Orbiter)

Ground Penetrating Radar – Basic Terms

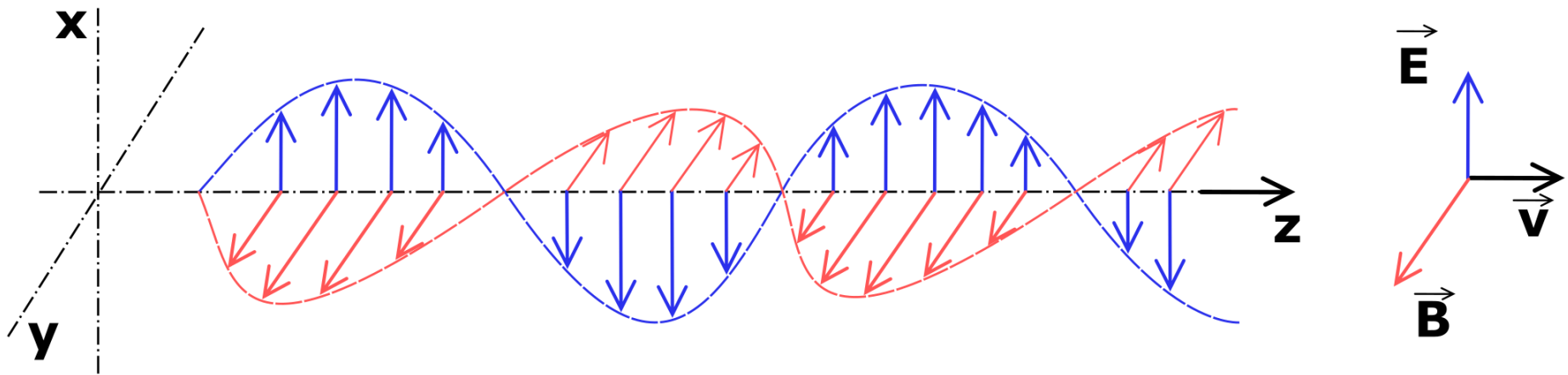

Leonardo da Vinci (1452-1519)

“Everything in the cosmos is propagated by means of waves...”

Manuscript H, 67r, Institut de France, Paris.

“I say: if you throw two small stones at the same time on a sheet of motionless water at some distance from each other, you will observe that around the two percussions numerous separate circles are formed; these will meet as they increase in size and then penetrate and intersect one another, all the while maintaining as their respective centers the spots struck by the stones.”

Manuscript A, 61r, Institut de France, Paris.

Basic Terms

Huygens (1678) ...

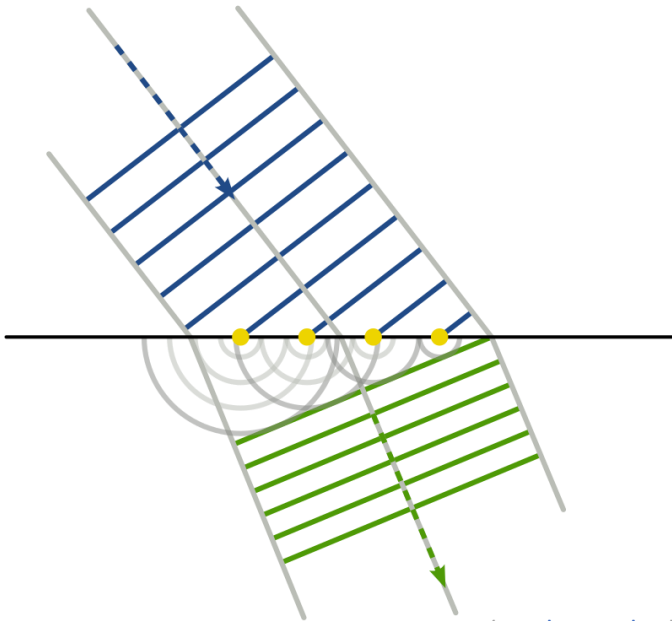

([Wikipedia](#))

- Reflection and refraction of waves at the boundary of a discontinuous medium / or heterogeneity.

...–Fresnel (1816) principle

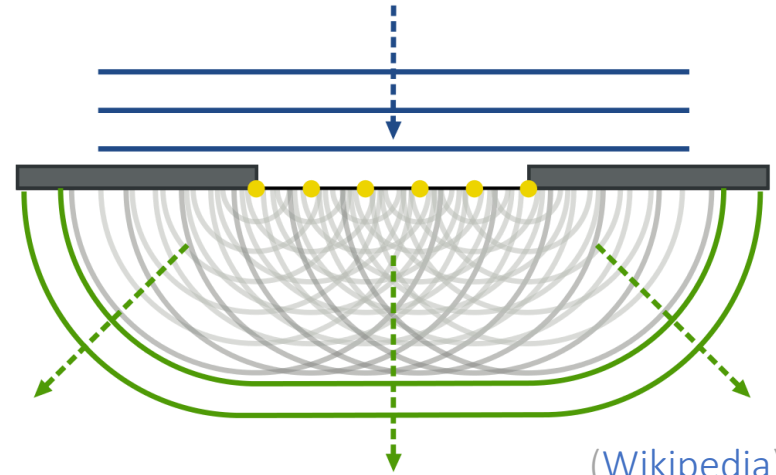

([Wikipedia](#))

- Diffraction of the resulting wave can be calculated by superposition of all elementary waves.

Basic Terms

EM-wavelet

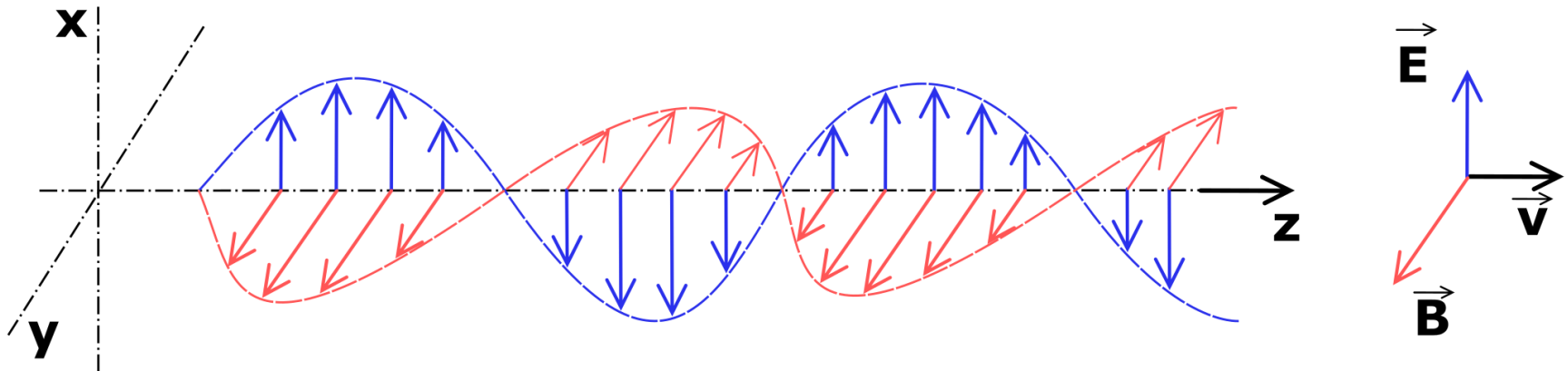

GPR-EM-pulse

- transmittance of high-frequency (~ 12.5 MHz – 2.5 GHz) electromagnetic pulses as a continuous wave train into the subsurface (transmitting antenna)
- reflection or refraction at inhomogeneities are received (receiving antenna)
- travel time and amplitude give information about the structure and depth of the inhomogeneities

Basic Terms

Electromagnetic spectrum

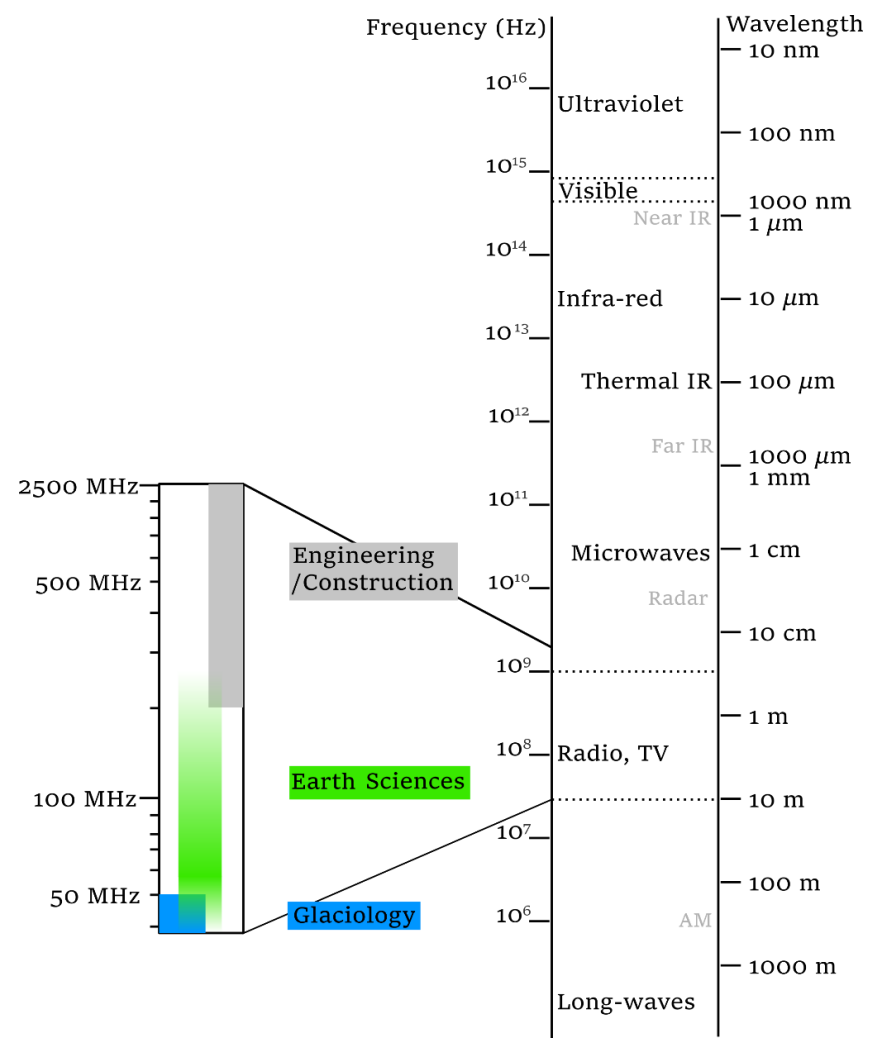

GPR-pulse characteristics

- short (~ 20 ns), highly pulsed signal ($12\,500 - 500\,000$ s⁻¹)
- high band width with center frequency (‘Mexican hat’)
- resolution $\sim \frac{1}{4}$ of wavelength
- amplitude less than 1 mW

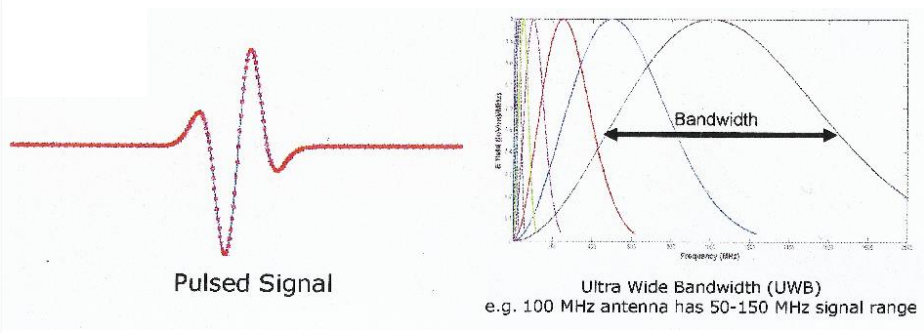

Propagation of electromagnetic waves

Material	ϵ_r	Material	ϵ_r
Air	1	Saturated Sand	25
Ice	3	Silts	30
Dry Sand	5	Clays	40
Granite	6	Fresh Water	80
Dry Salt	6	Sea Water	80
Limestone	8	Metal	∞
Shale	15		

Table from Telford 1990 Applied Geophysics

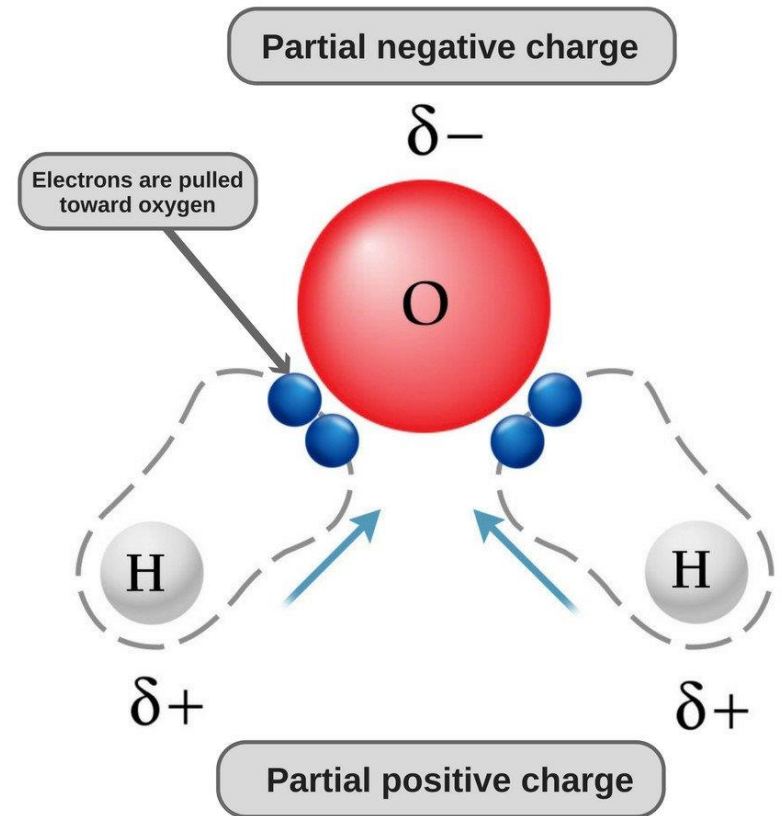

- Dielectric properties of water $\epsilon_r = 80$
- Electrical conductivity $\sigma_e = 0.15 \times \text{TDS mS/m}$
- Rotational relaxation at 10 000 MHz

Propagation of electromagnetic waves

The emitted electromagnetic waves are affected by

Dielectric permittivity ϵ_r

Magnetic susceptibility μ_r

Electrical conductivity σ_e

Reflection coefficient

Describes how much of an electromagnetic wave is reflected by an impedance discontinuity in the transmission medium.

Fraction of the reflected energy at the plane for normal

inclination is:

$$R = \frac{v_1 - v_2}{v_1 + v_2} = \frac{\sqrt{\epsilon_2} - \sqrt{\epsilon_1}}{\sqrt{\epsilon_2} + \sqrt{\epsilon_1}}$$

Basic Terms

Propagation of electromagnetic waves

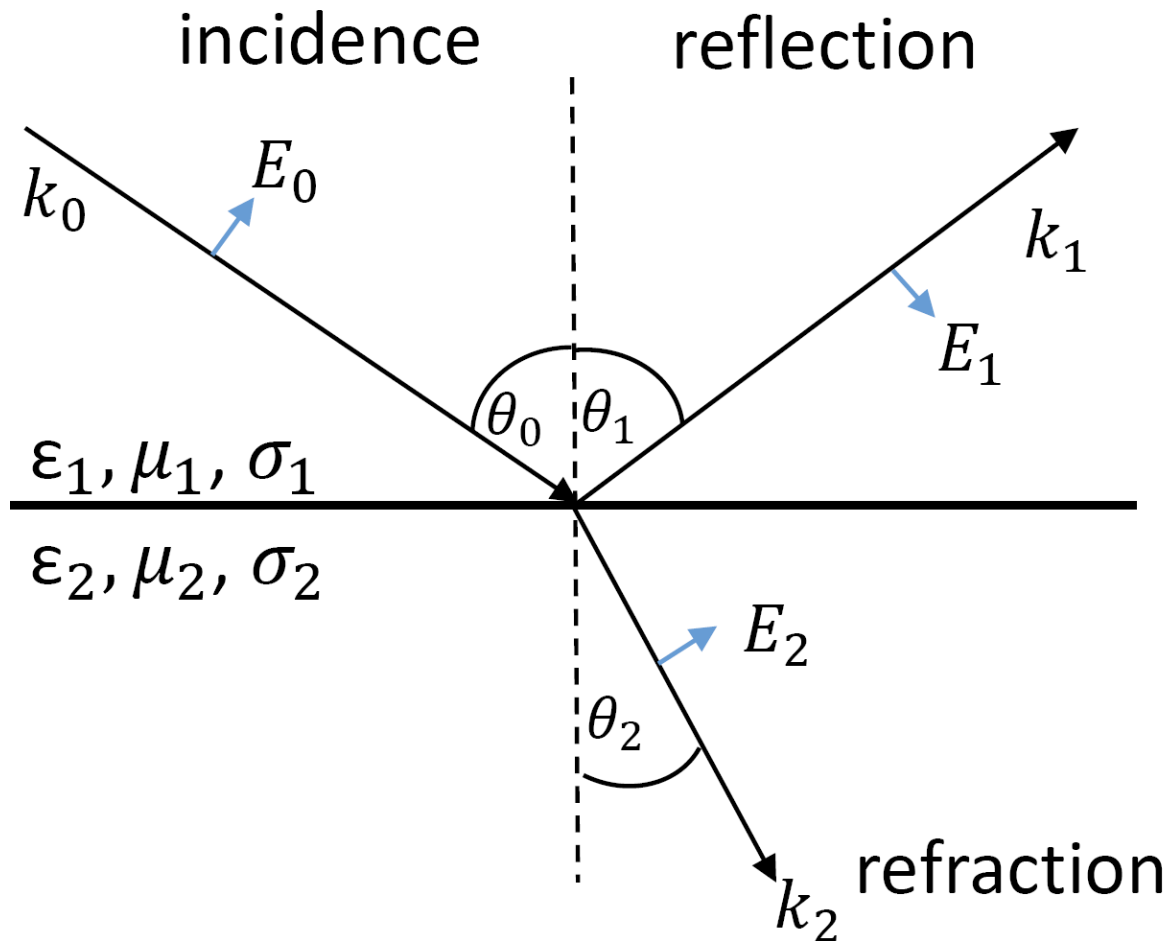

Basic Terms

Propagation of electromagnetic waves

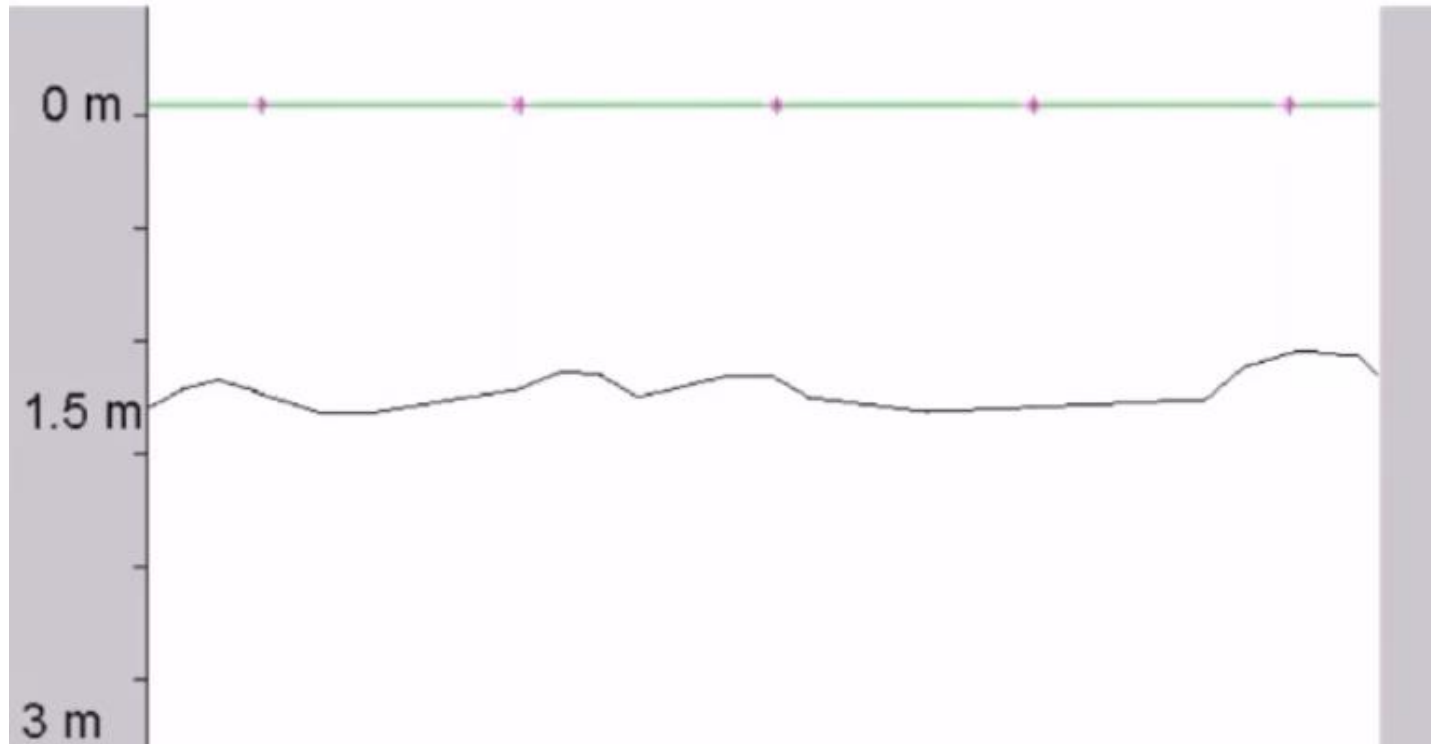

- 30 % reflects and 70 % transmits through

Radar velocity

Material	Conductivity σ [mS/m]	Permittivity ϵ_r	Radar velocity (m/ns)
Air	0	1	0.3
Fresh water	0.5	80	0.033
Salt water	3000	81-88	0.01
Dry sand	0.01	3-10	0.15
Wet sand	0.1 -1	20-30	0.06
Limestone	0.5 – 2	4-8	0.12
Shale	1-100	5-15	0.09
Clay	2-1000	5-40	.06-.17
Granite	0.01 – 1	4-6	0.13
Ice	0.01	3-4	0.16
Concrete	.01-10	6	0.09

Values are approximate and are from various sources including Geophysical Survey Systems, Inc. (1987); Schultz (2002); Milsom (2003); Davis and Annan (1989); Conyers (2004)

Radar velocity

Velocity (v) of an electromagnetic wave is a function of its frequency (f), the speed of light in free space, and the host medium's relative dielectric permittivity (ϵ_r), relative magnetic permeability (μ_r) and σ .

Mathematically it is defined as:

$$v = \frac{c_0}{\sqrt{\epsilon_r \mu_r \frac{1 + \sqrt{1 + (\sigma/\omega\epsilon)^2}}{2}}}$$

For non-magnetic materials it can be simplified to: $v = \frac{c_0}{\sqrt{\epsilon_r}}$

Radar velocity

Medium	Relative dielectric permittivity (ϵ_r)	Electromagnetic-wave velocity (m ns^{-1})
Air	1	0.3
Fresh water	80	0.03
Seawater	80	0.01
Unsaturated sand	2.55–7.5	0.1–0.2
Saturated sand	20–31.6	0.05–0.08
Unsaturated sand and gravel	3.5–6.5	0.09–0.13
Saturated sand and gravel	15.5–17.5	0.06
Unsaturated silt	2.5–5	0.09–0.12
Saturated silt	22–30	0.05–0.07
Unsaturated clay	2.5–5	0.09–0.12
Saturated clay	15–40	0.05–0.07
Unsaturated till	7.4–21.1	0.1–0.12*
Saturated till	24–34	0.1–0.12*
Freshwater peat	57–80	0.03–0.06
Bedrock	4–6	0.12–0.13

(Neal and Roberts 2000) $\text{Time} = (\text{Two-way distance})/\text{Velocity} = (1 \text{ m})/(3 \times 10^8 \text{ m/s}) = 3 \times 10^{-9} \text{ s} = 3 \text{ ns}$.

$\lambda = v/f = (1.3 \times 10^8 \text{ m/s})/200 \text{ MHz} = (1.3 \times 10^8 \text{ m/s})/(200 \times 10^6 \text{ Hz}) = 0.65 \text{ m}$.

Basic Terms

Radar frequencies

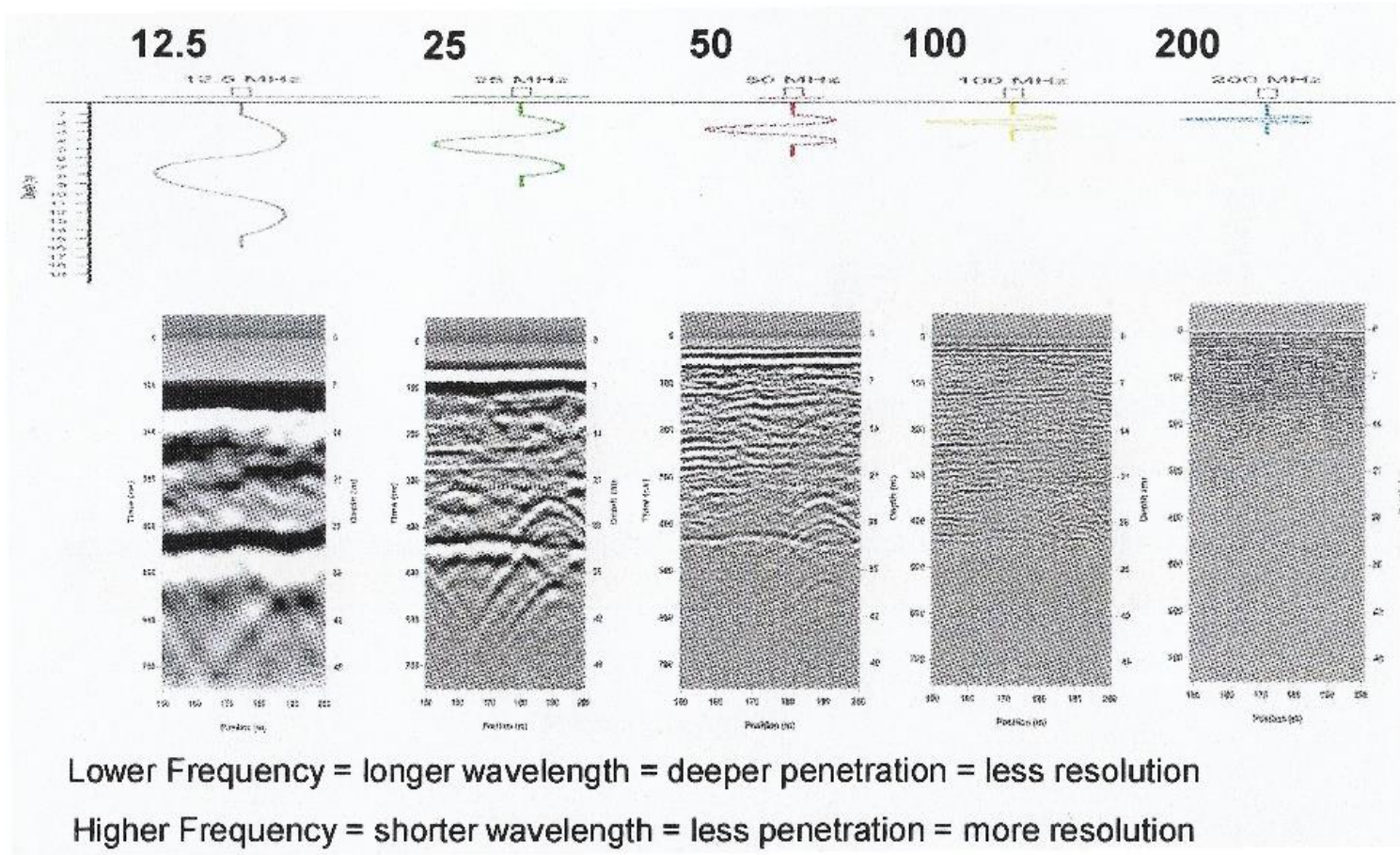

Ground Penetrating Radar - Measurement principle



Measurement principle

Antennas and signals

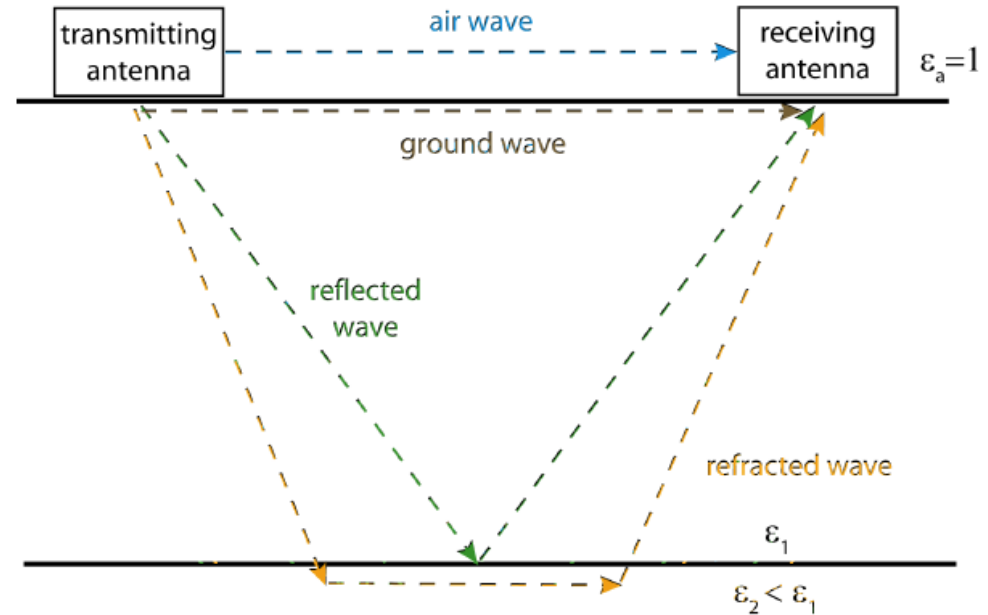

Ludwig et al. (2011)

- transmitting and receiving antenna
- radar wave propagates through the air and soil
- velocity of the wave depends on the dielectric properties
- when dielectric properties of the different media change, the electromagnetic wave is partially reflected
- travel time and amplitude of the wave is recorded by the receiving antenna

Measurement principle

Antennas and signals

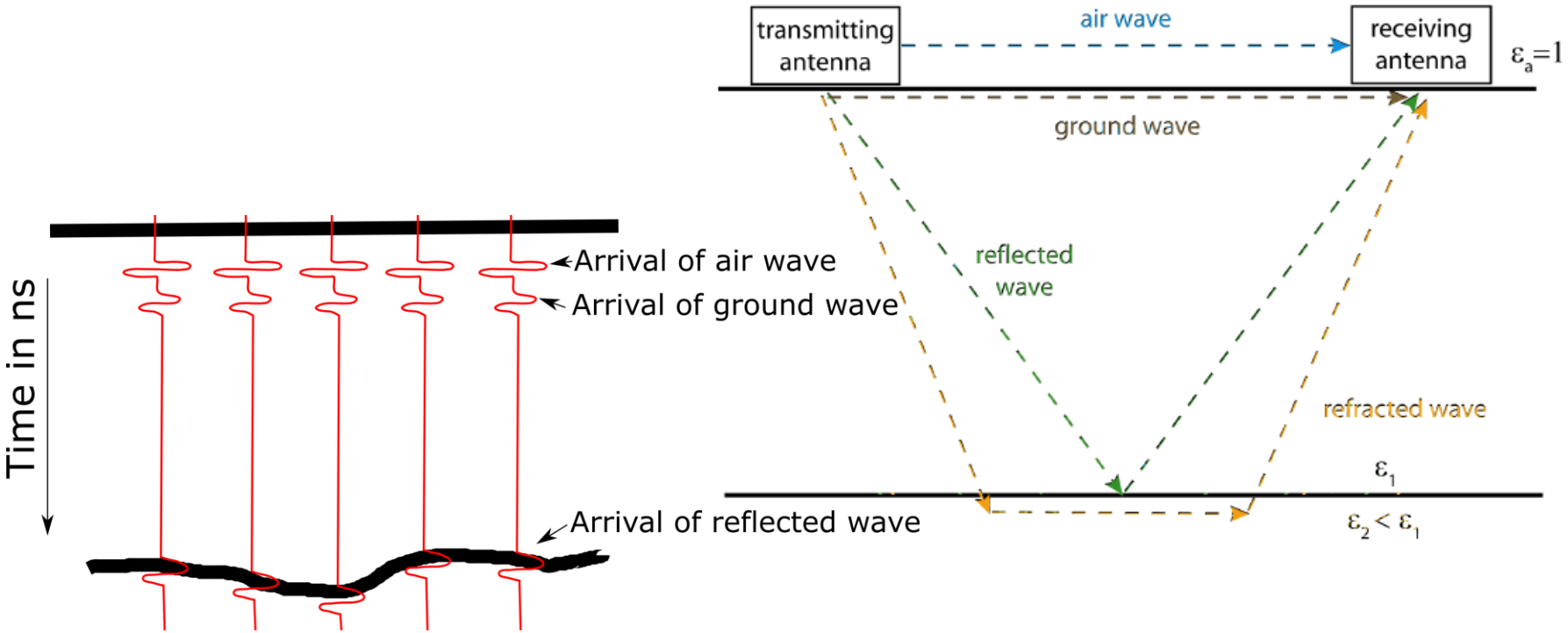

Measurement principle

Antennas and signals

- emitted waves reach receiving antenna at different times
- record (trace) of amplitudes (mV) as a function of time (TWT [ns])

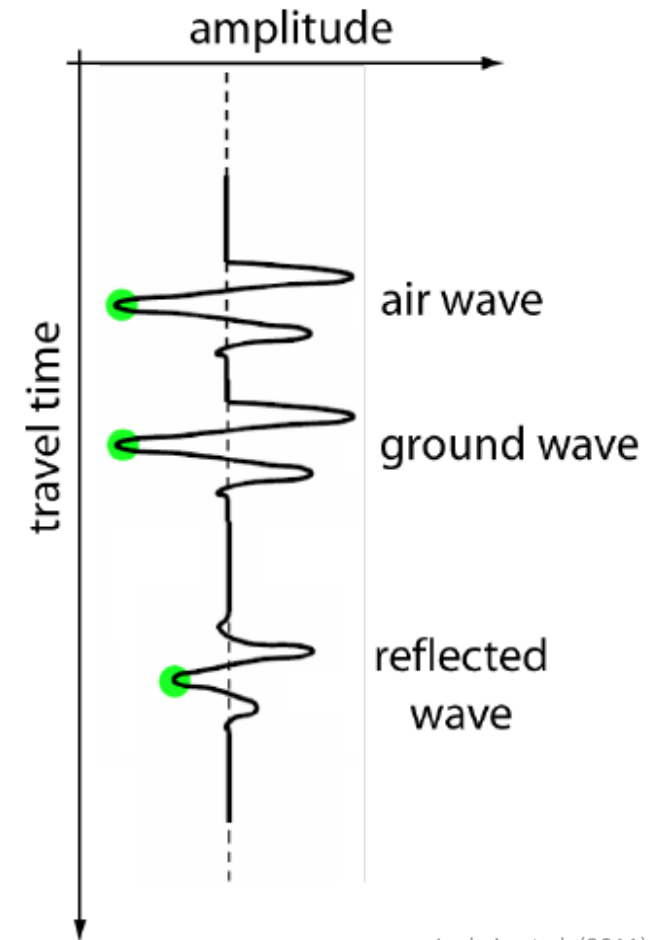

Ludwig et al. (2011)

Measurement principle

Antennas and signals

- In a standard GPR measurement, the antennas are pulled along the survey track while traces are triggered at a fixed interval by a measurement wheel which is connected to the back of the antenna. This results in a series of traces which are finally displayed by the measurement software as a function of position and time in a so-called radargram.
- The sampling interval and the antenna frequency has to follow the Nyquist-Shannon sampling

theorem: $f_{Nyq} = \frac{1}{2\Delta t} > f_{max}$ (f_{max} is \sim antenna frequency + 50%)

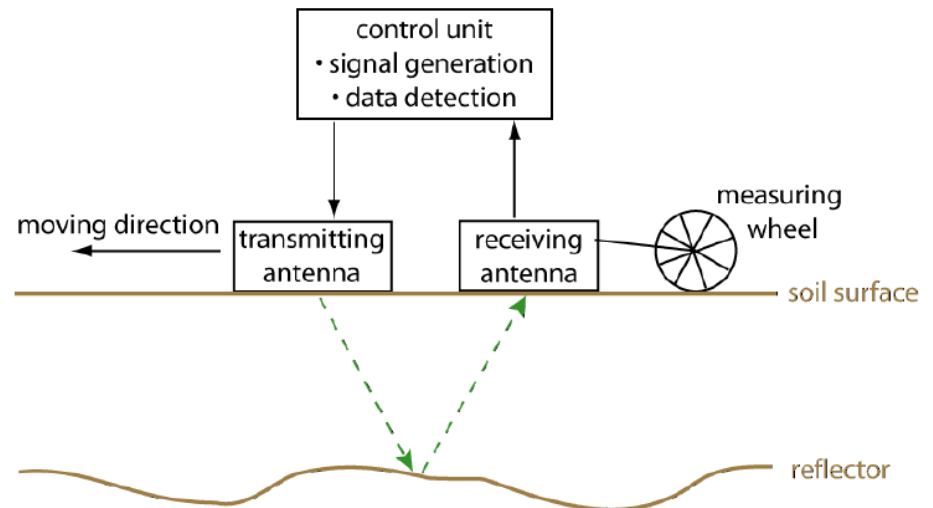

Measurement principle

Antennas and signals

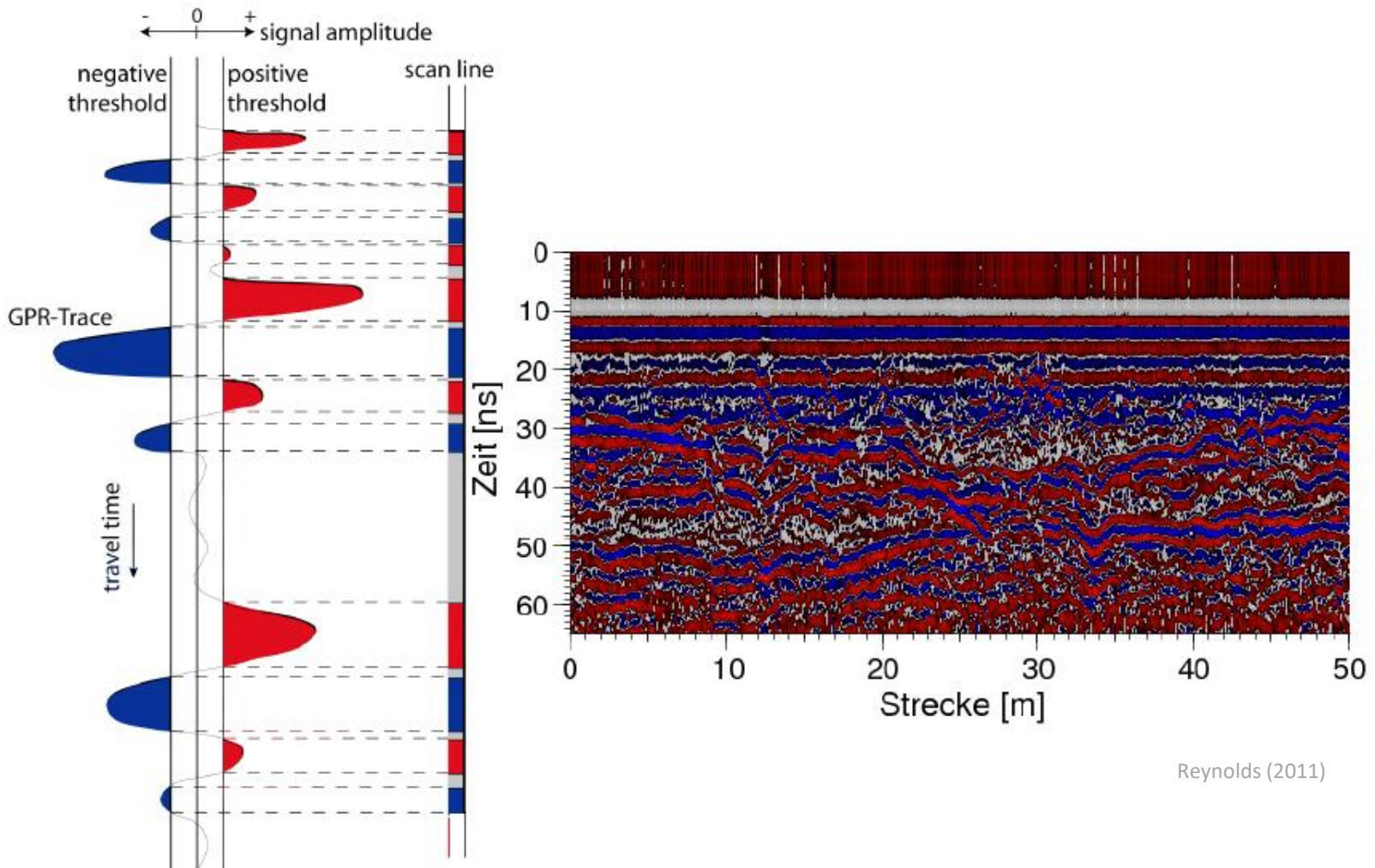

Reynolds (2011)

Measurement principle

Energy loss and Penetration

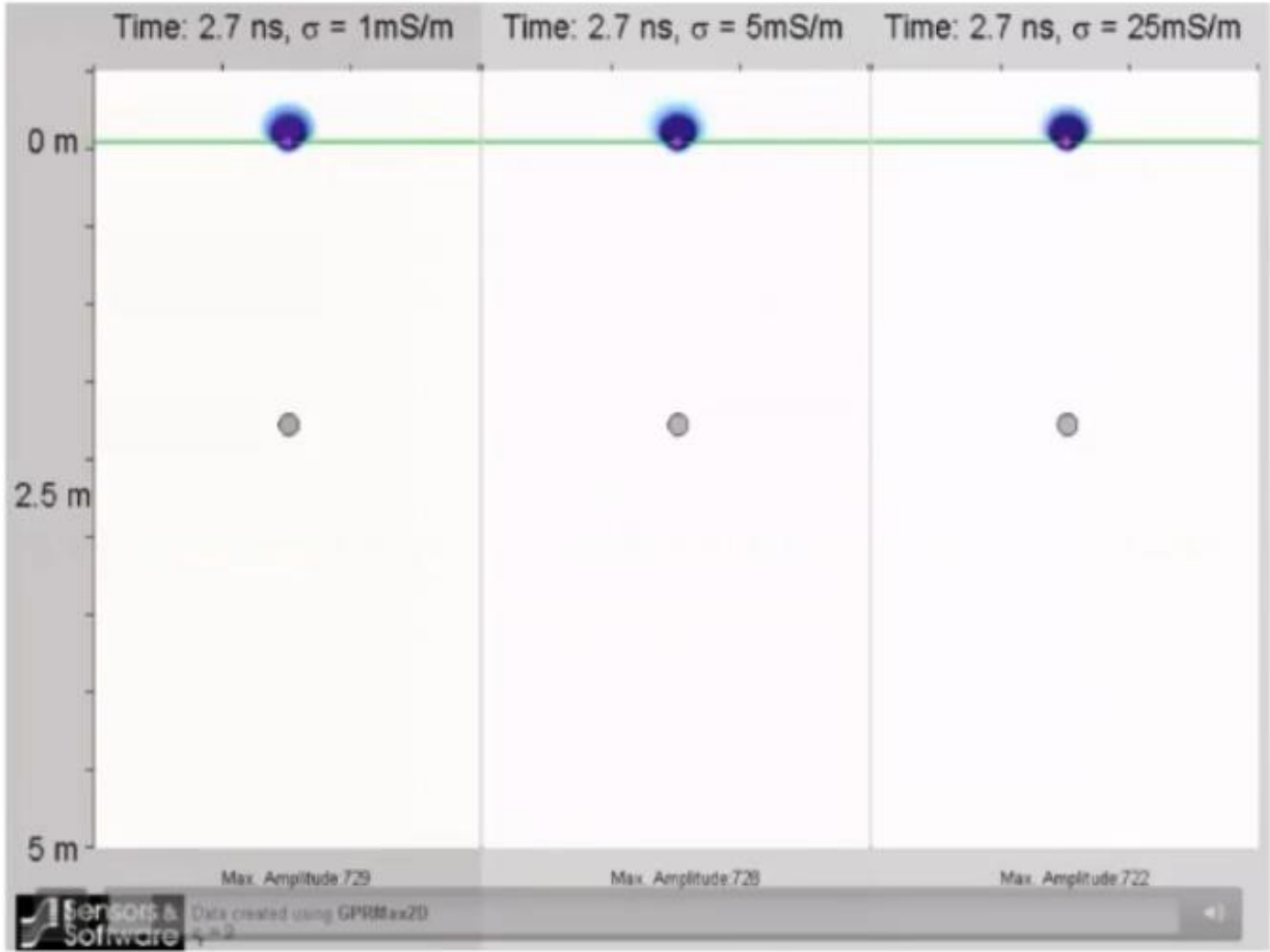

Measurement principle

Energy loss and Penetration

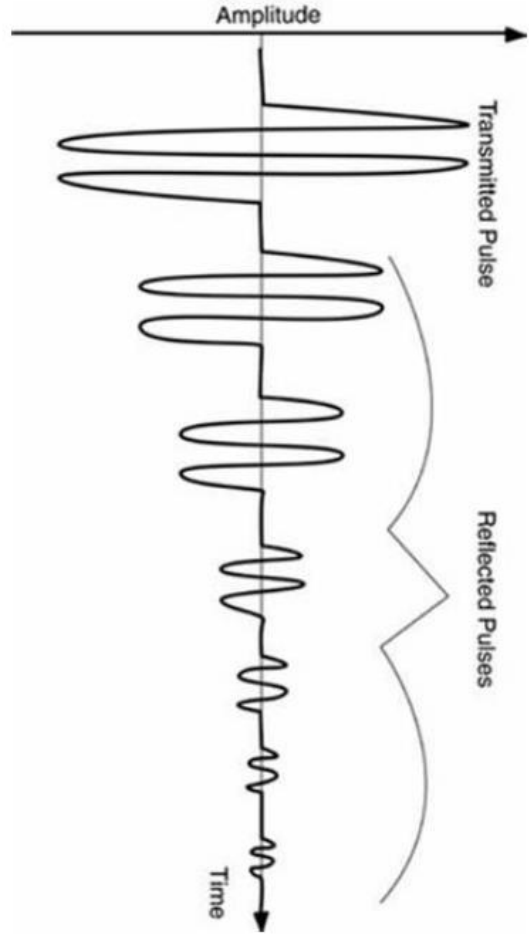
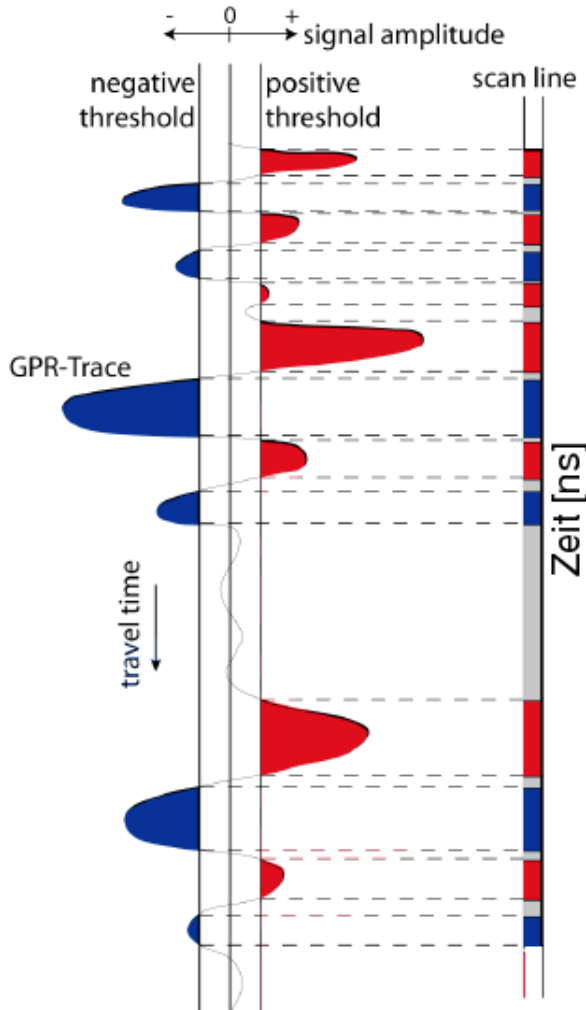

- 1) Signal Attenuation (absorption)
- 2) Signal scattering
- 3) Spherical Spreading

Reynolds (2011)

Measurement principle

Energy loss and Penetration

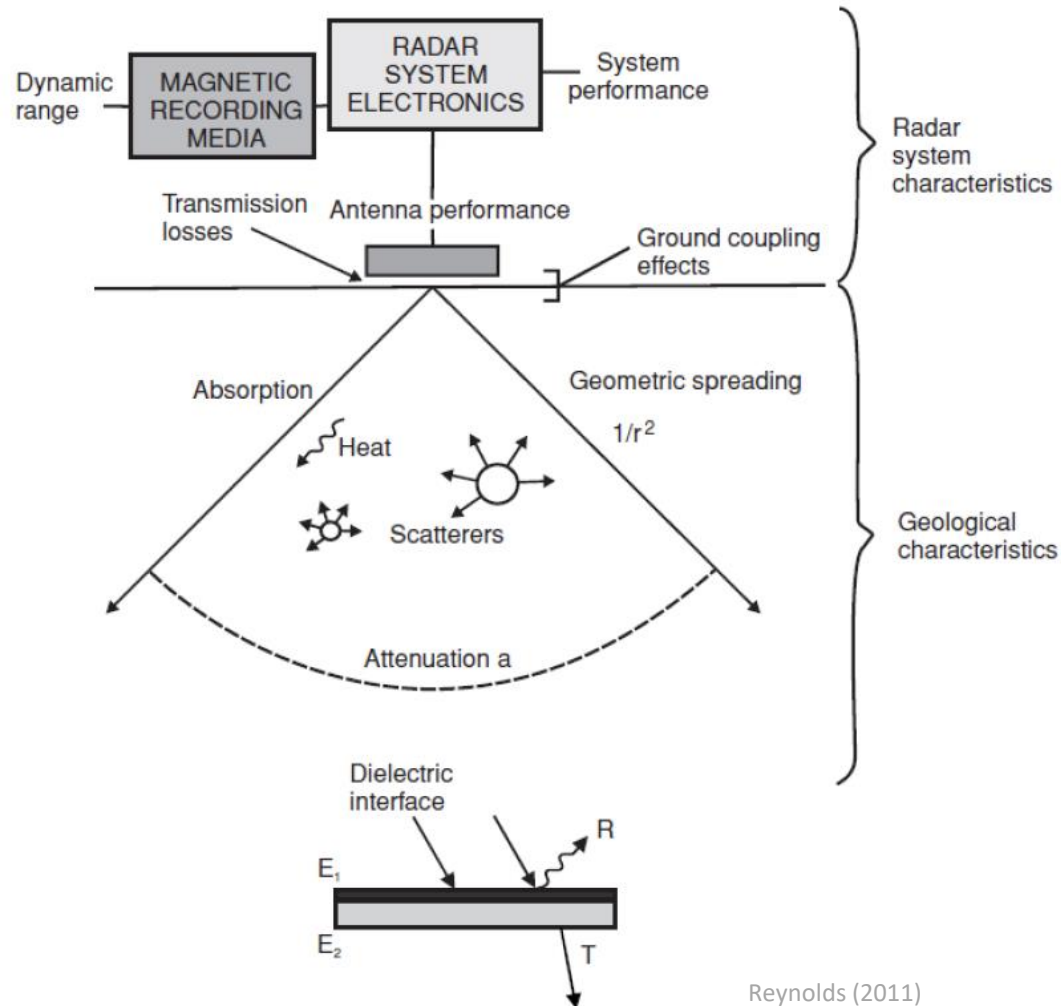

Measurement principle

Energy loss and Penetration

- The largest amount of energy loss results from damping of free charge carrier movement. The material dependent attenuation is induced by the direct current electric conductivity σ_{dc} of the investigated medium. Depending on the traveled distance x the amplitude E of the electromagnetic wave decreases exponential with respect to its starting value E_0 :

$$E(x) = E_0 e^{-\beta x}, \quad \text{with } \beta = \frac{\sigma_{dc}}{2c_0 \epsilon_0 \sqrt{\epsilon}}$$

- The higher σ_{dc} of the medium, the higher is the attenuation of the electromagnetic wave. In soils, electrical conductivity for example increases due to an increasing in soil moisture content, clay content or amount of dissolved solutes in the solution.
- The penetration depth of the electromagnetic waves reduces with increasing electrical conductivity of the medium. For salt water the penetration depth is only 1cm:

$$\delta = \frac{1}{\beta}$$

Measurement principle

Signal processing

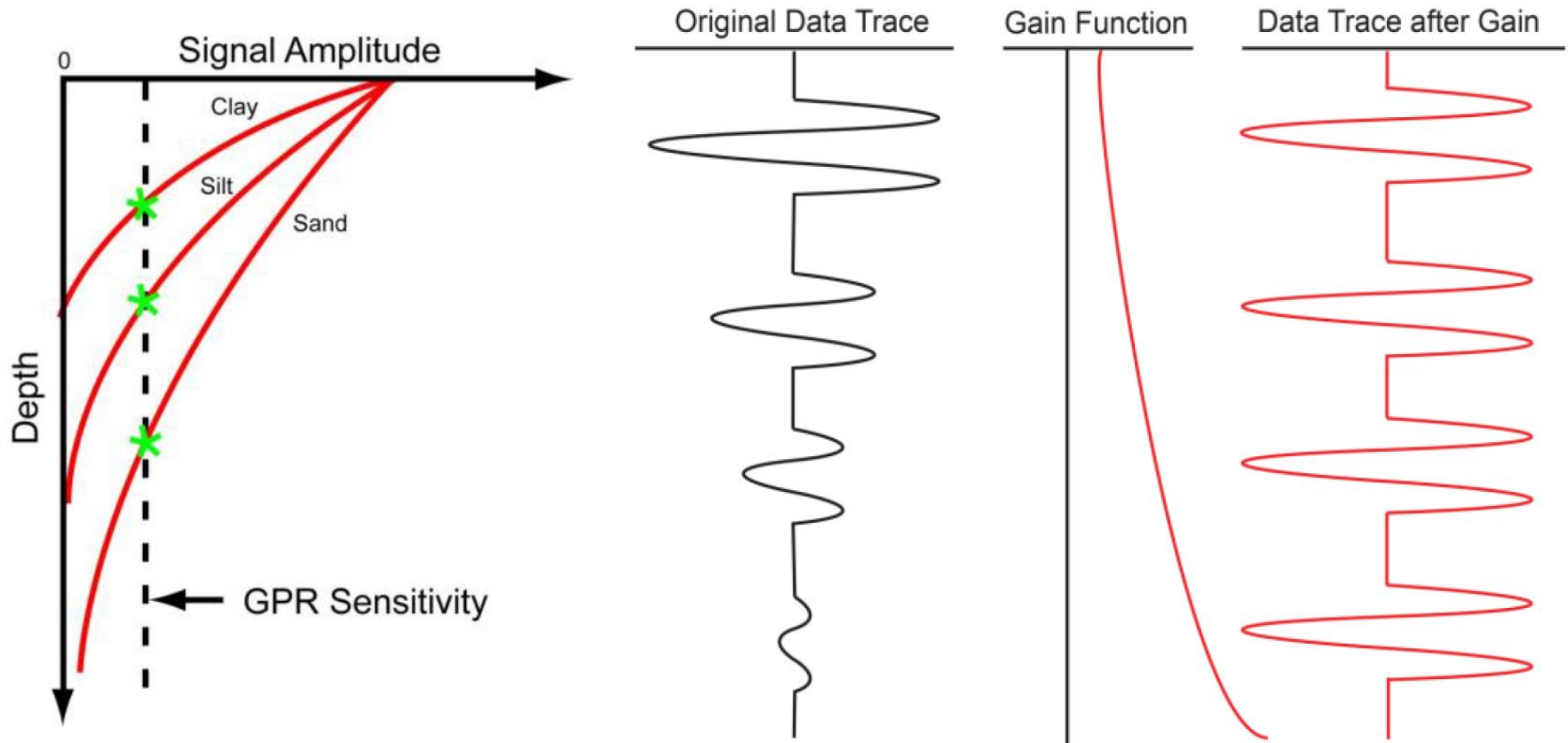

Measurement principle

Signal processing

Spreading & Exponential Compensation (SEC) Gain

Raw GPR Line with No Gain

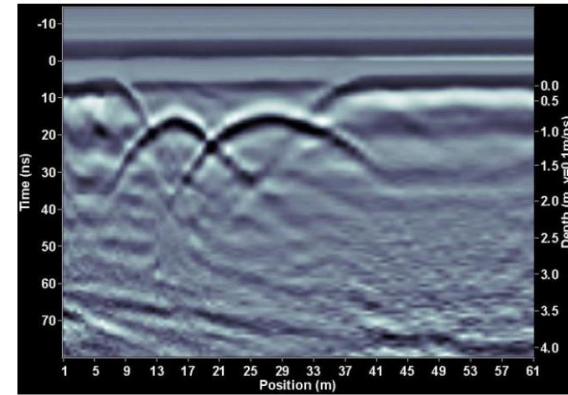
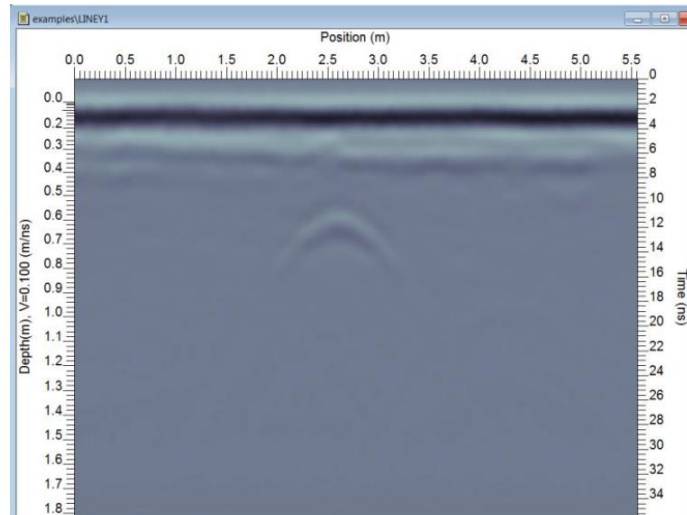

AGC Gain

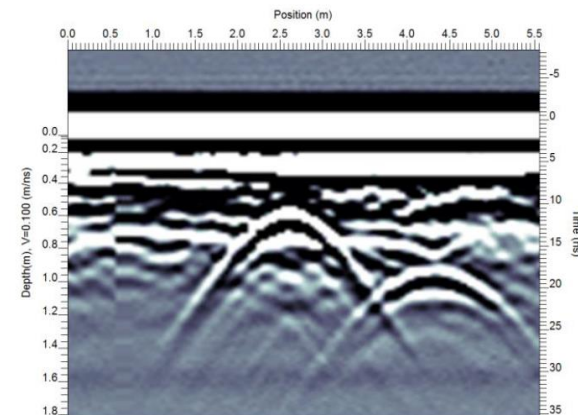

Measurement principle

Signal processing

If data are properly gained with an SEC-type gain, we can make inferences about the strength of reflections

AGC

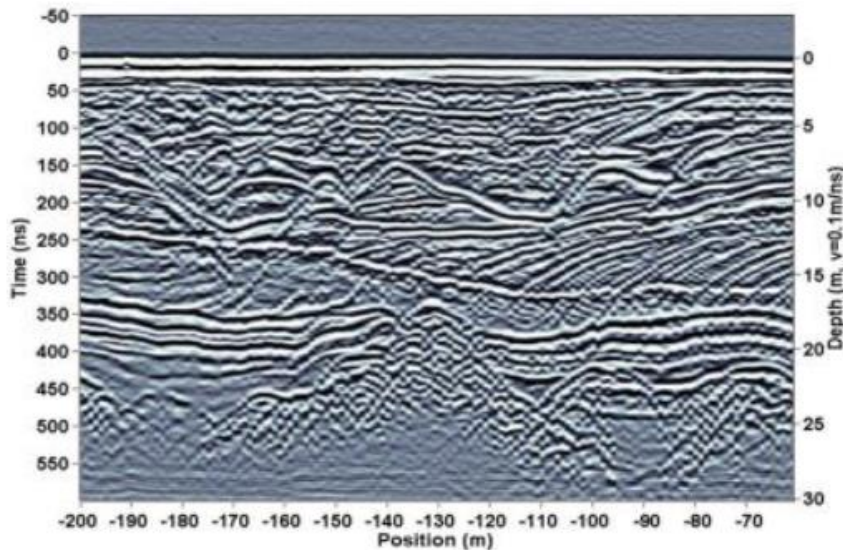

SEC

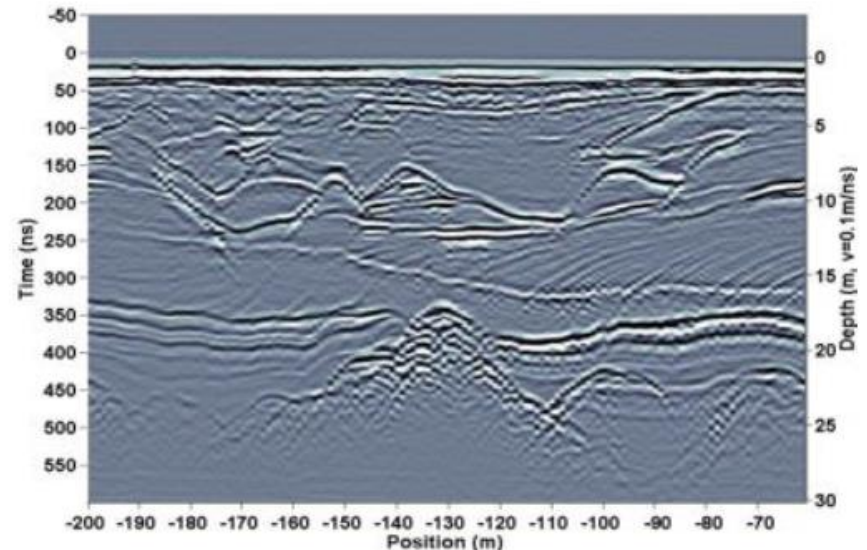

Measurement principle

Signal processing

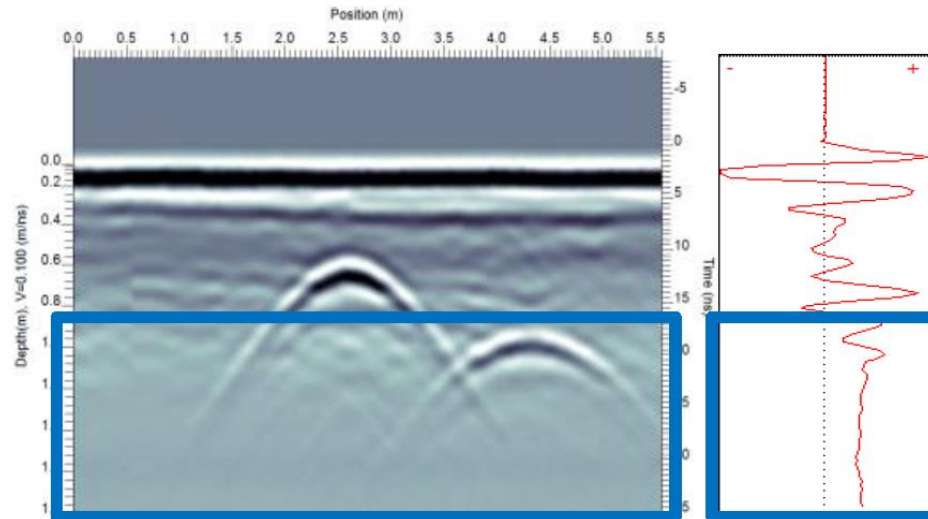

Trace and Data Section with **WOW**

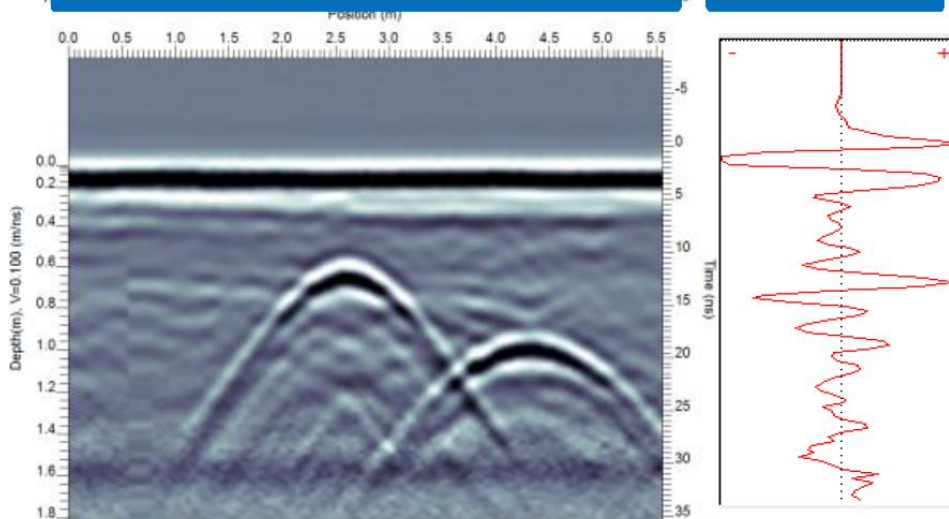

Trace and Data Section after applying **DEWOW** filter

Ground Penetrating Radar - Surveys

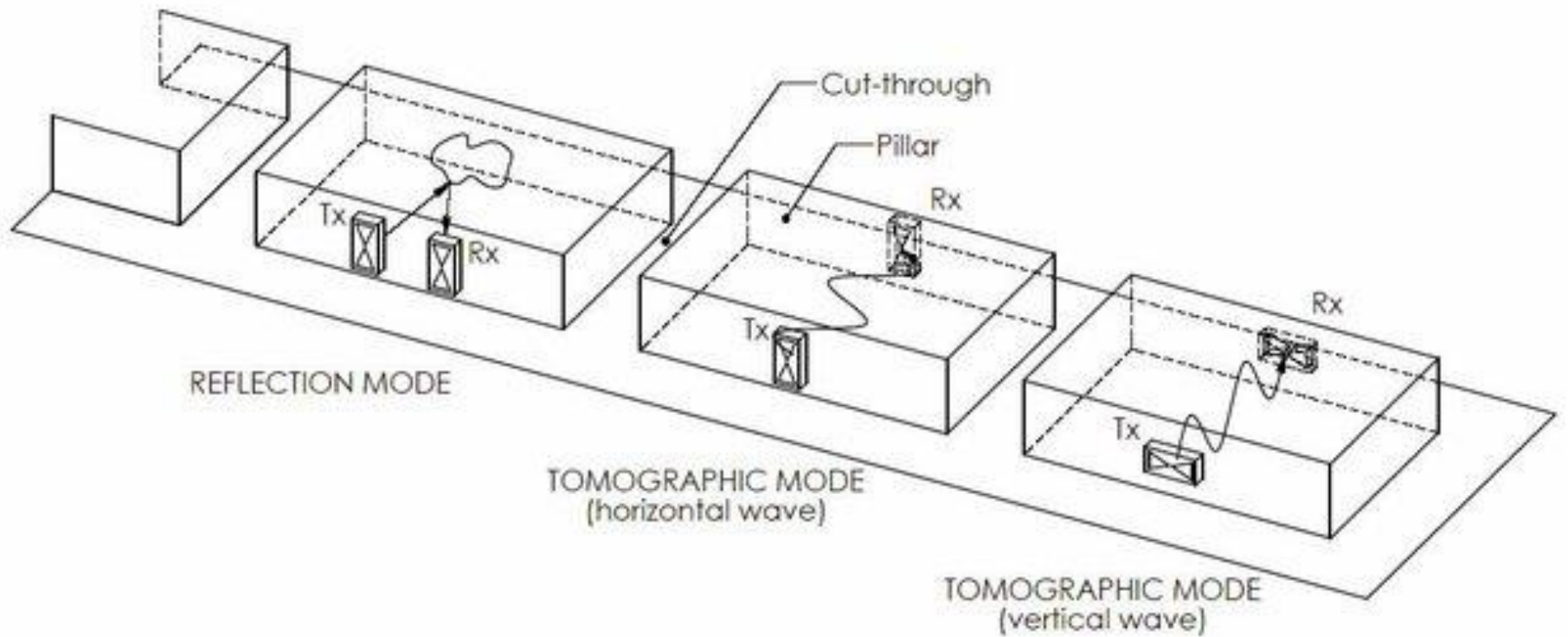

Trace

Trace: Recorded amplitudes [mV] as a function of Two-way-travel time [ns] of the reflected or GPR signal.

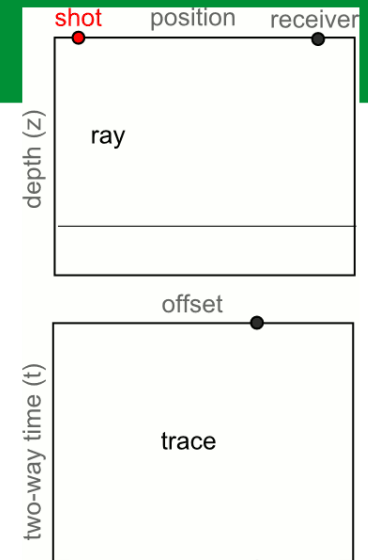

Common offset (CO)

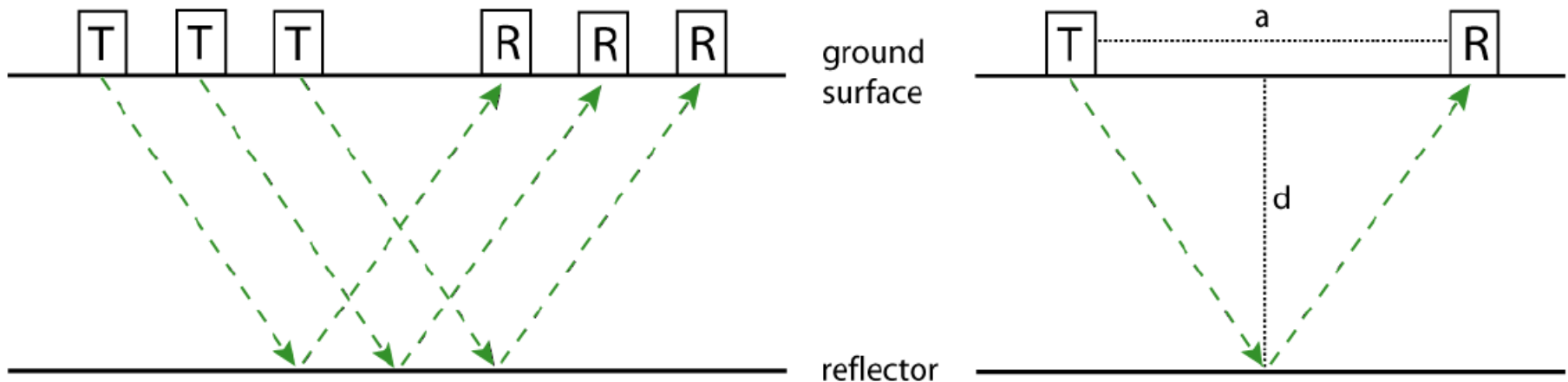

Common offset (CO)

Is the simplest and most widespread GPR measurement technique.

Transmitter and receiver antenna are moved along the survey track while the distance between both antenna is kept constant. Electromagnetic pulses are emitted at equidistant intervals which are controlled by the survey wheel.

From the measured travel time t of the reflected signal the depth d of a horizontal reflector can be determined by:

$$s = 2 \cdot \sqrt{d^2 + \left(\frac{a}{2}\right)^2} = \sqrt{4d^2 + a^2} \quad \text{with } a \text{ as distance between antennas.}$$

Assuming a homogeneous medium the travel time is determined by:

$$t = \frac{s}{v} = \frac{\sqrt{4d^2 + a^2}}{\frac{c}{\sqrt{\epsilon}}}$$

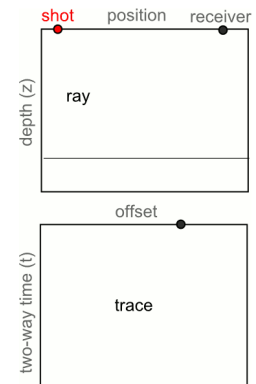

CO: velocity analysis / diffraction hyperbola



CO: velocity analysis / diffraction hyperbola

$$\text{Time} = t = 2(x^2 + h^2)^{\frac{1}{2}}/V_1$$

$$t^2 = 4(x^2 + h^2)/V_1^2 = (4/V_1^2)x^2 + 4h^2/V_1^2$$

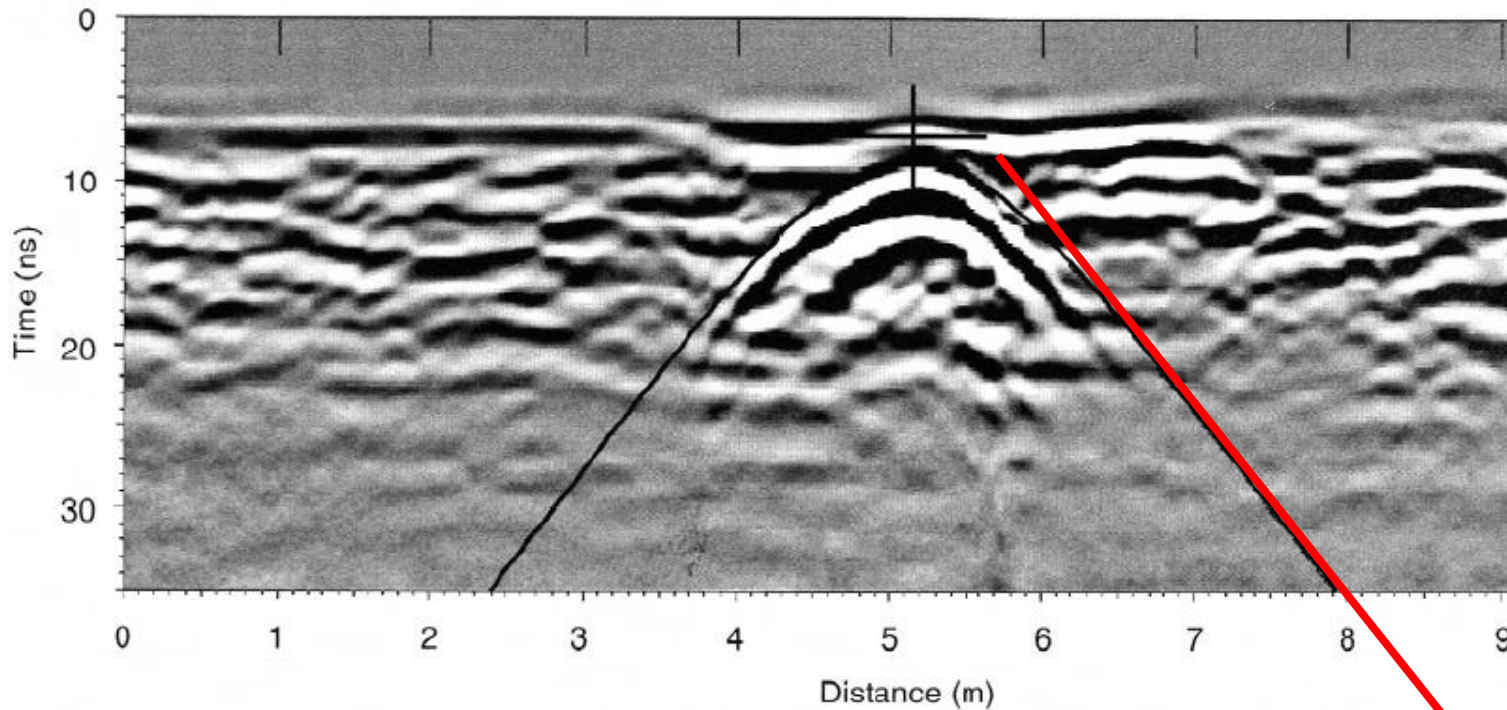

$$t_0^2 = 4h^2/V_1^2$$

$$t_0 = 2h/V_1$$

$$h = t_0 V_1 / 2$$

$$\text{slope} = 1/V_1$$

CO: velocity analysis / diffraction hyperbola

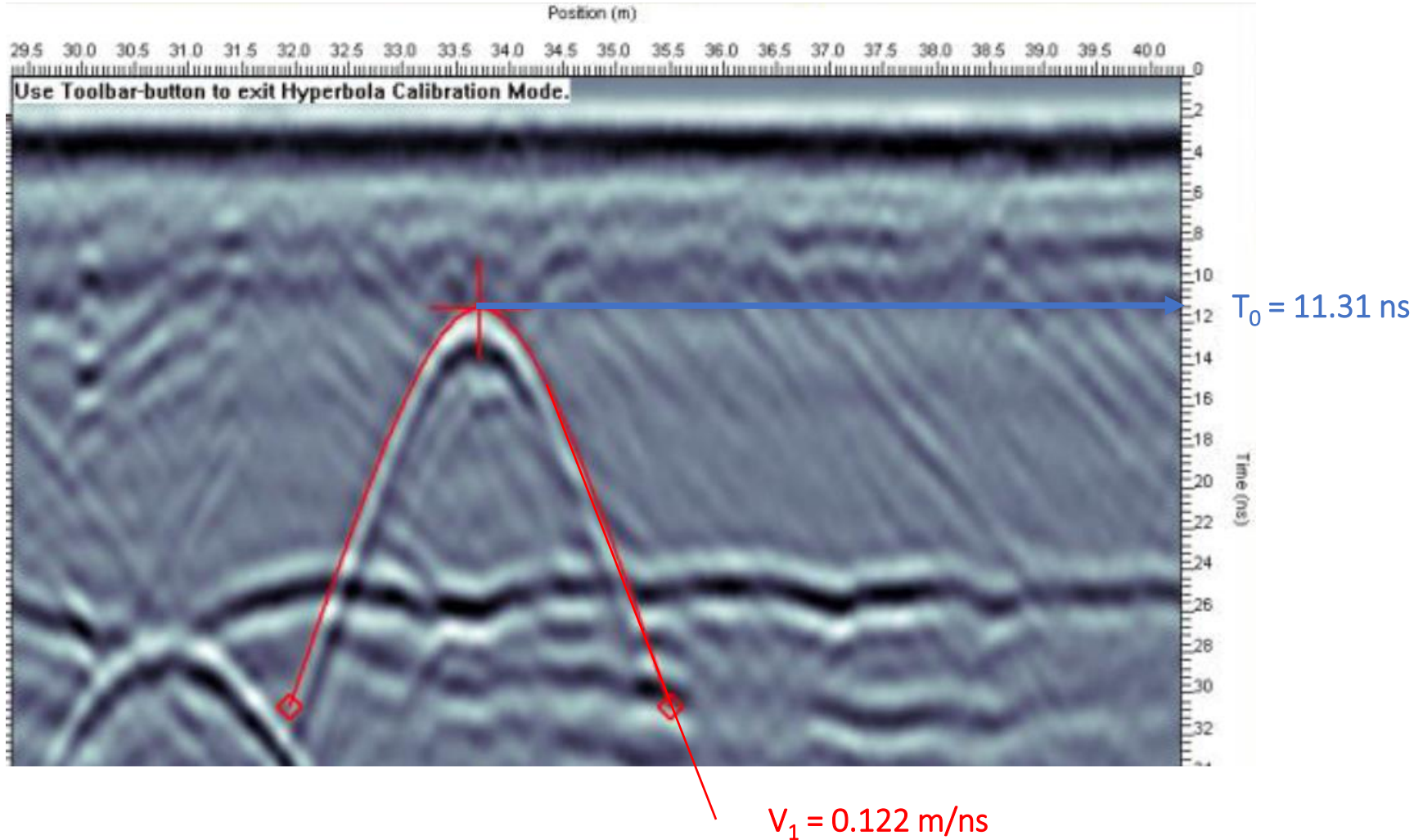

Multi offset: Common midpoint

In a common-midpoint measurement (CMP) transmitter and receiver are moved away from each other in equidistant steps. The resulting radargram displays the travel time as a function of the antenna separation.

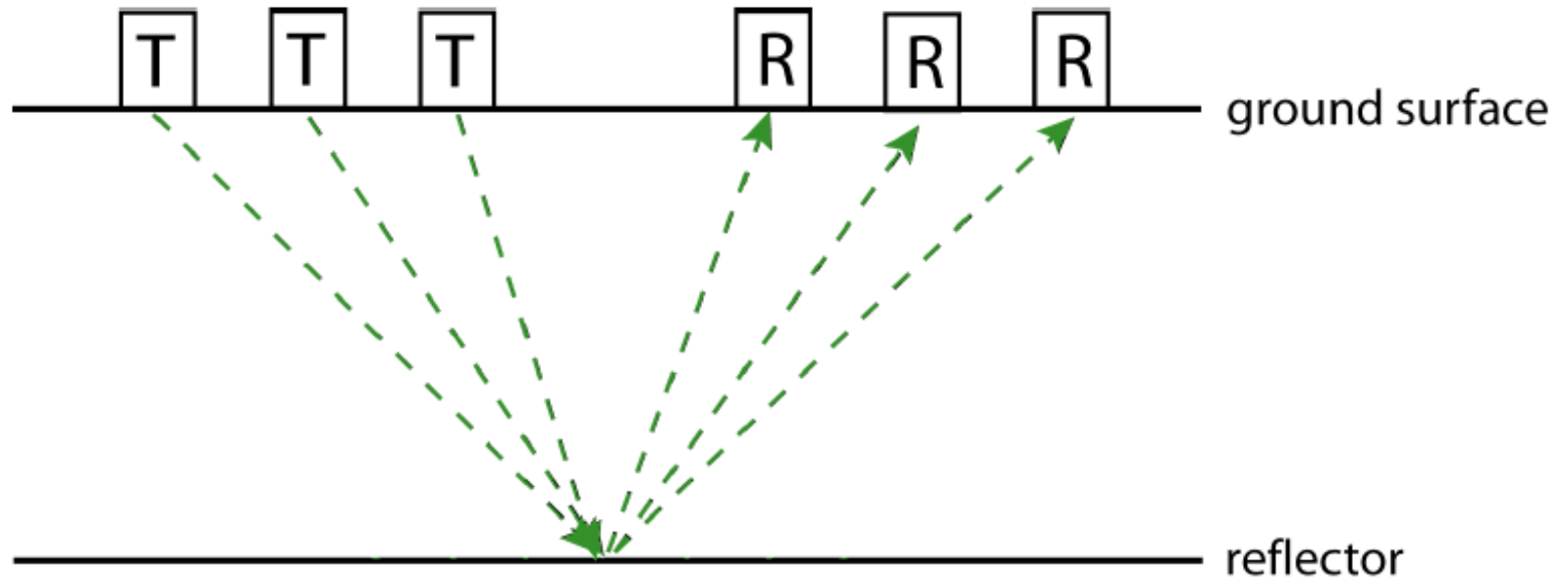

Multi offset: Common midpoint

- Air and ground wave travel directly between the antenna.
- Linear relationship between the travel time t and the antenna separation a with the constant of proportionality $\frac{1}{v}$:

$$t = \frac{a}{v}, \text{ with } v = c \text{ (airwave) and } v = \frac{c}{\sqrt{\epsilon}} \text{ (groundwave)}$$

- Reflector depth below the midpoint between the transmitting and the receiving antenna: the relation between travel time t reflector depth is given by:

$$s = 2 \cdot \sqrt{d^2 + \left(\frac{a}{2}\right)^2} = \sqrt{4d^2 + a^2}$$

- Plotting the measured data in a t^2 - a^2 -diagram, leads to a linear relationship between t and a :

$$t^2 = \frac{1}{v^2} a^2 + \frac{4h^2}{v^2}$$

Multi offset: Wide Angle Reflection and Refraction (WARR)

- Only the transmitting or receiving antenna is moved along the measurement line while the other antenna stays stationary.
- In principle, a WARR measurement follows the same relationships concerning travel time as a CMP measurement. The difference is that the reflection point moves along the reflector. This is why a WARR measurement strictly is only applicable in the presence of horizontal or slightly sloping reflectors and material properties are homogeneous.

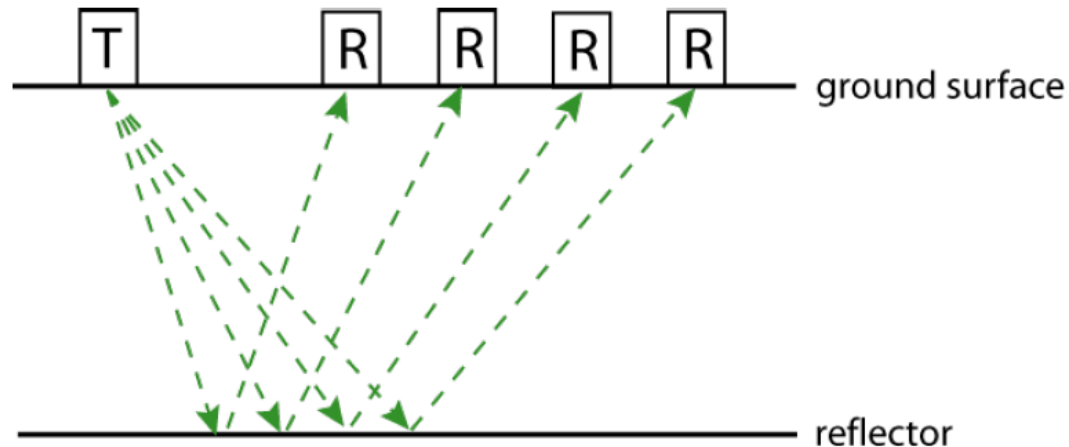

- CMP and WARR measurements provide more information than a CO measurement. The drawback of these techniques is the high measurement effort since both procedures only provide point information for a specific location. Both methods are hardly applicable along long measurement lines

Multi offset: velocity analysis

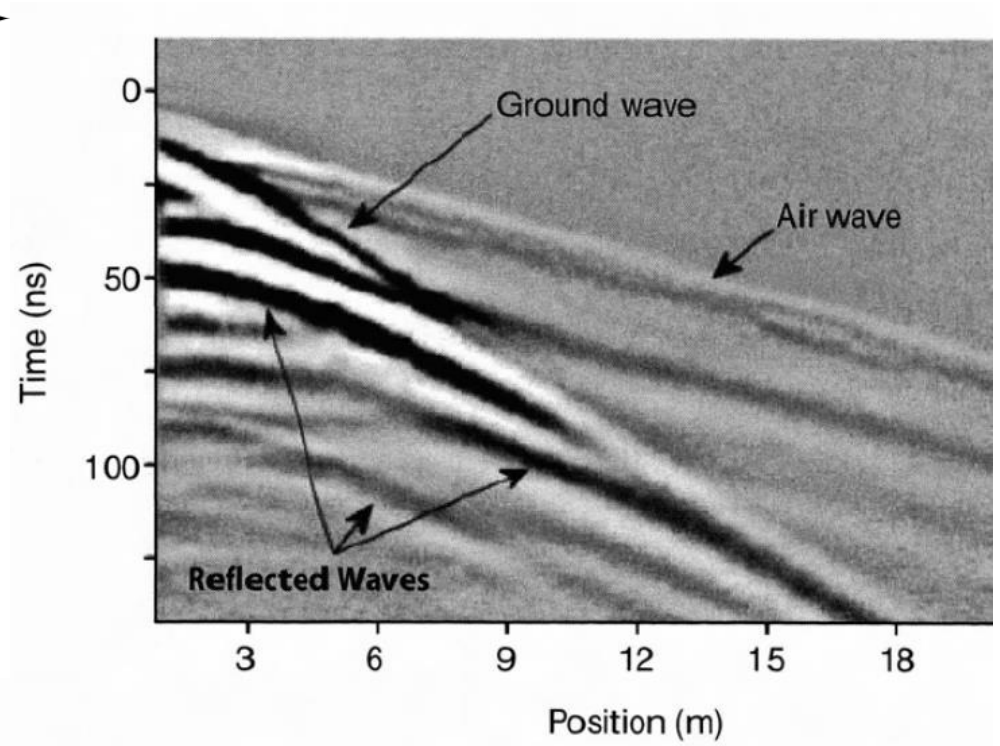
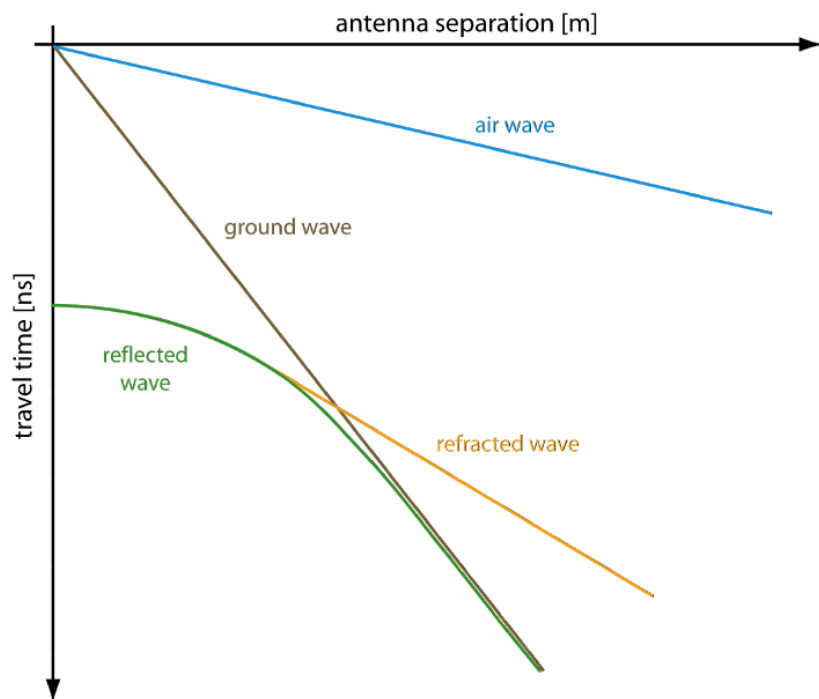

Burger et al. (1992)

Multi offset: velocity analysis

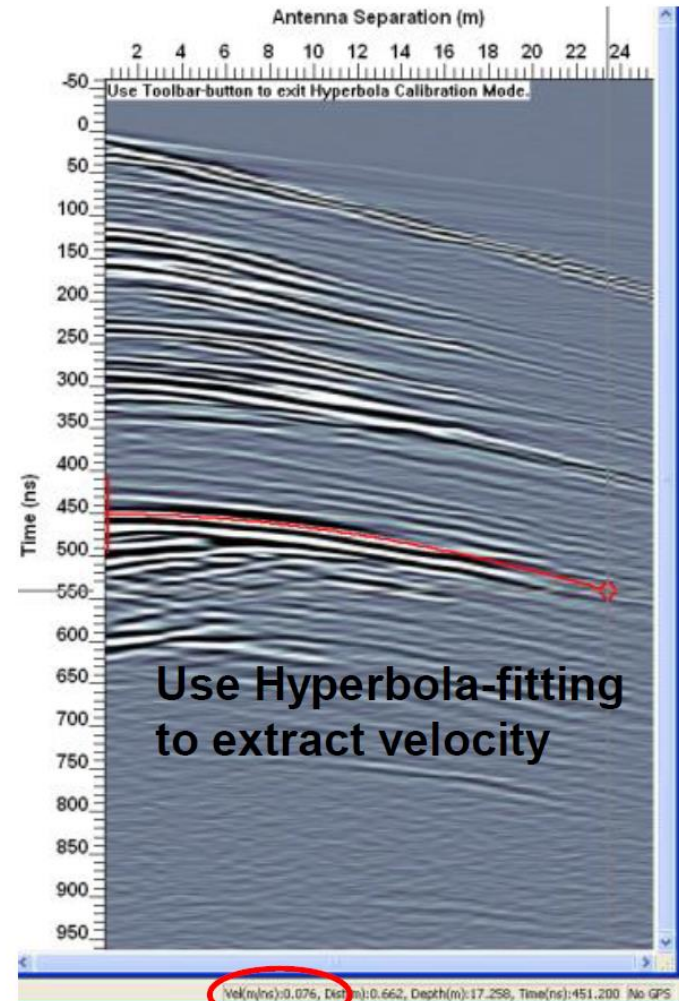
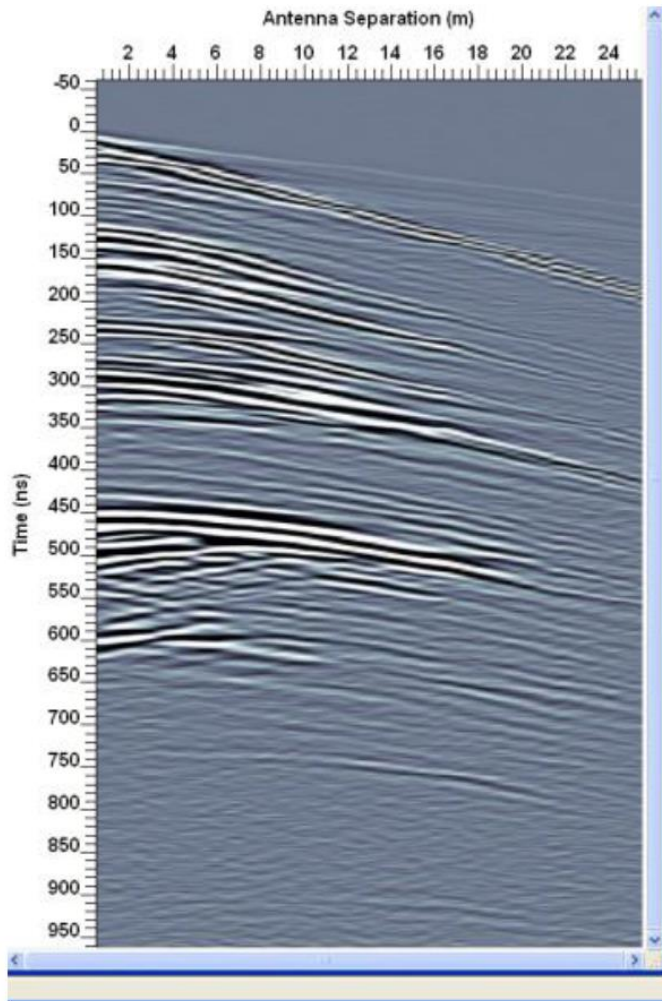

Field example



Fieldwork with ZOND 100 and 300 MHz antennas

Field example



Field example

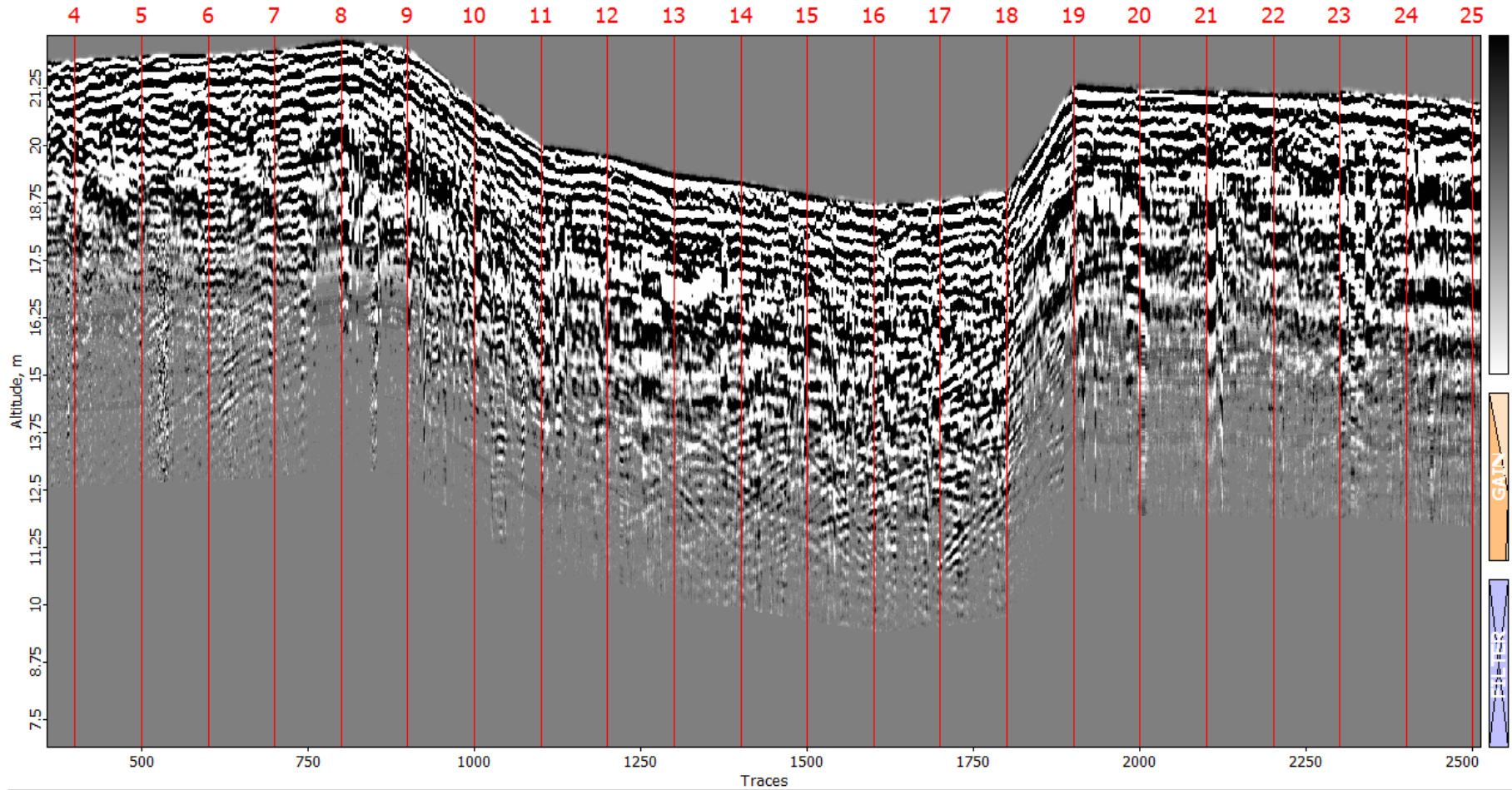

Radargram Kaali Crater, Estonia

Field example

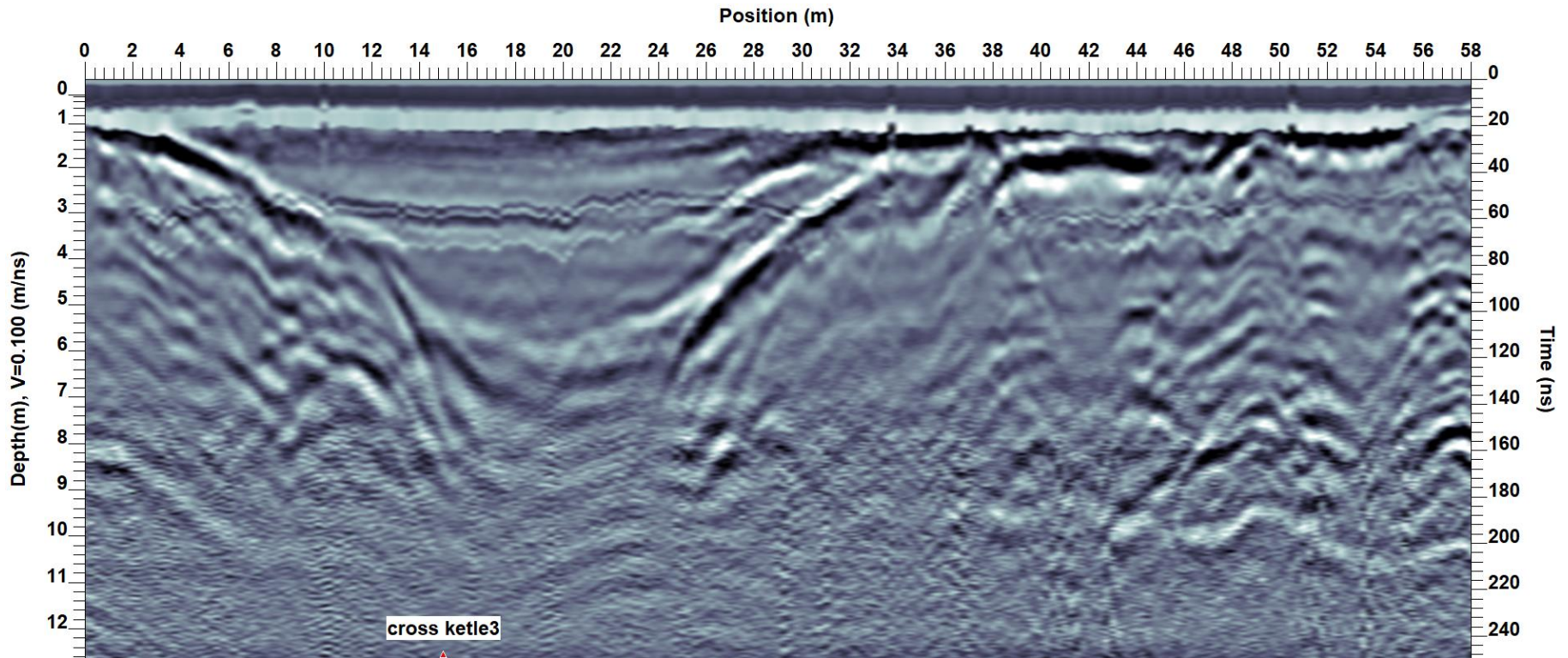

Kettle hole, Asylum Lake, Michigan, US

Field example

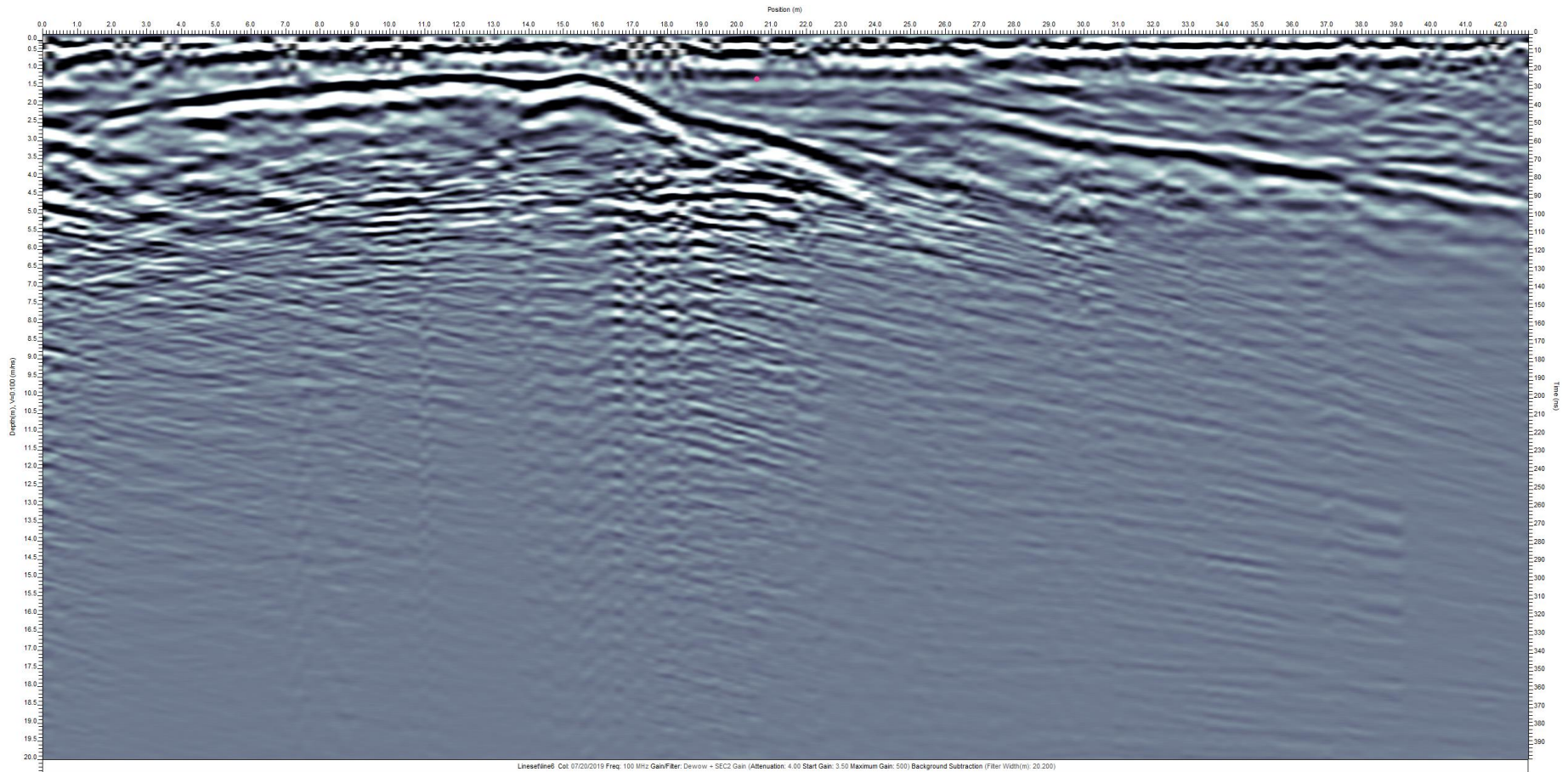

100 MHz; time window: 400 ns; common offset profile; length: 59 m; DEWOW + Gain (attenuation = 4); $v = 115$ mm/s

Pitfalls – ringing noise

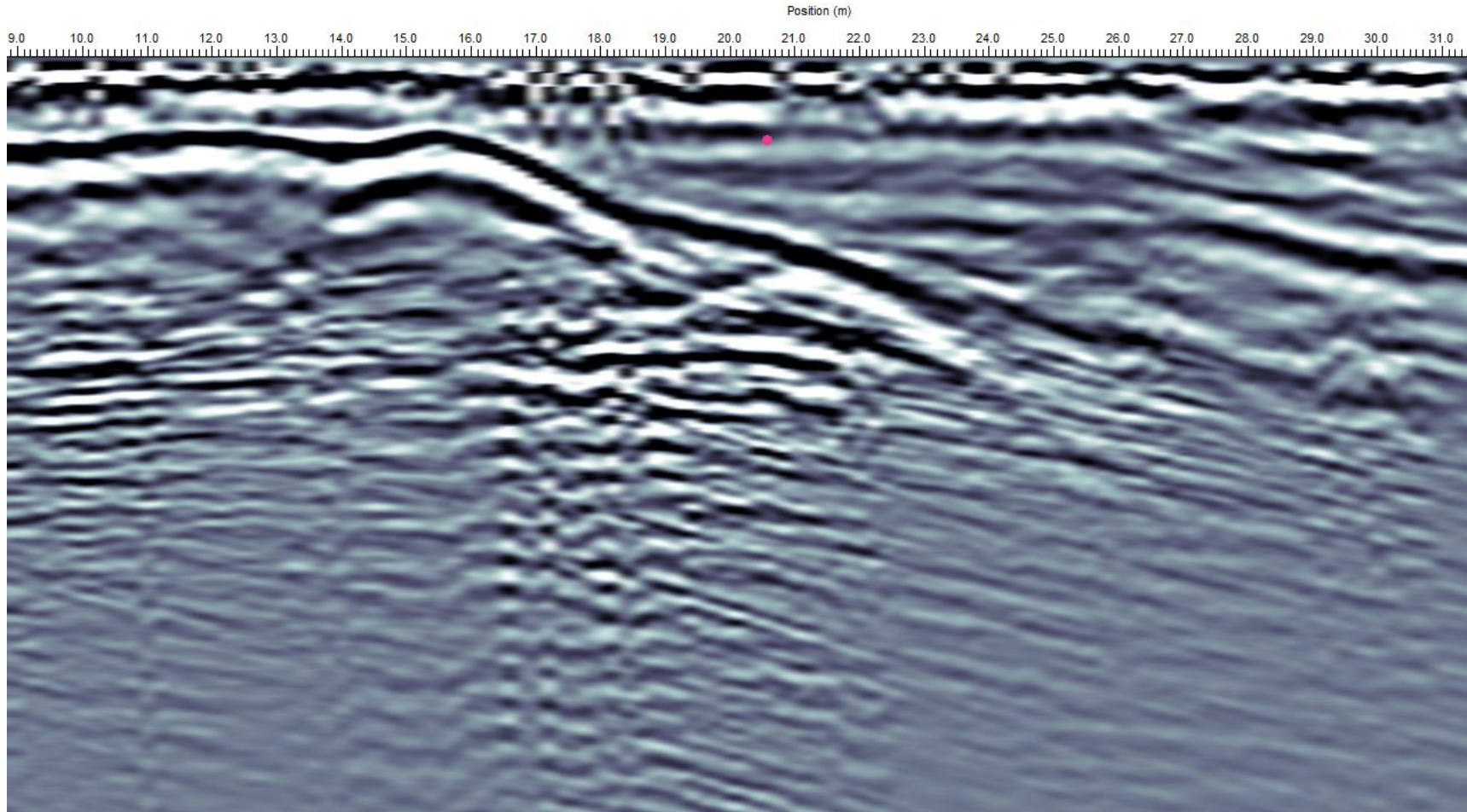

100 MHz; time window: 400 ns; common offset profile; length: 59 m; DEWOW + Gain (attenuation = 4); $v = 115$ mm/s

Pitfalls – ringing noise

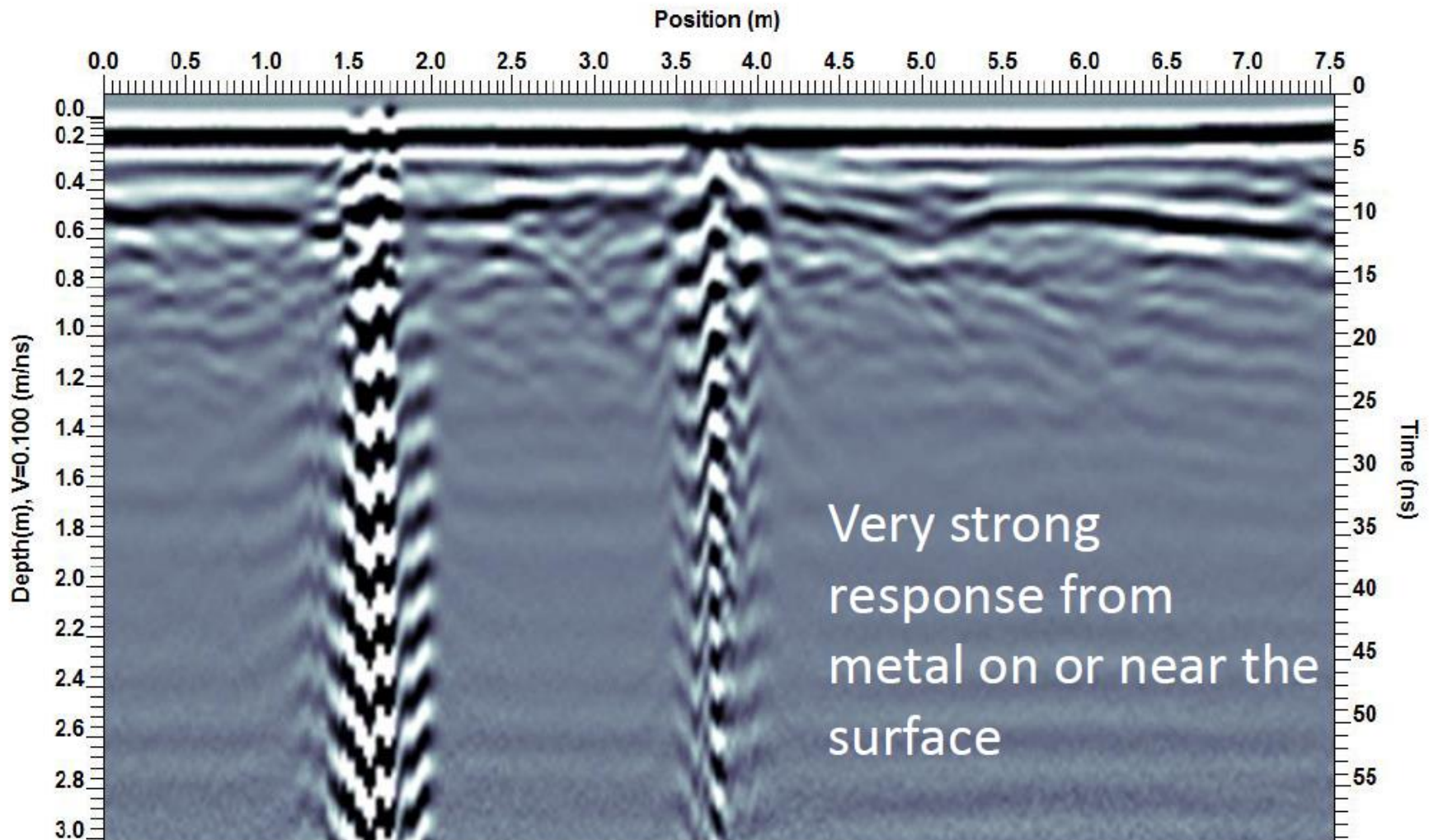

Field example

Why is one hyperbola wider than the other?

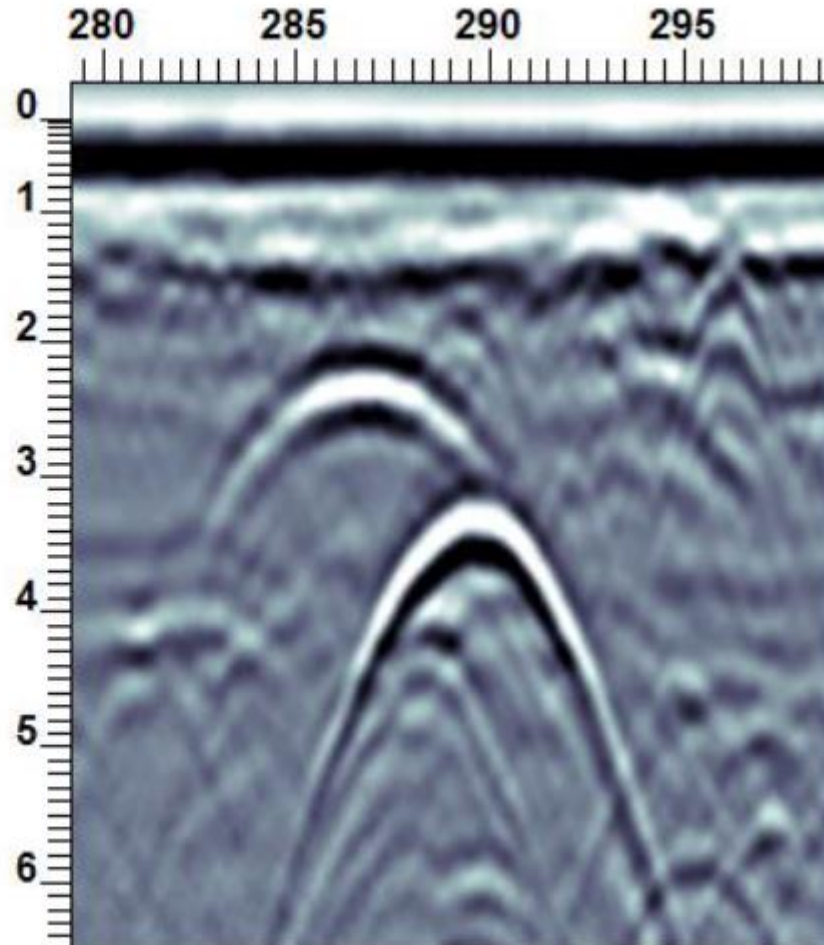

Field example

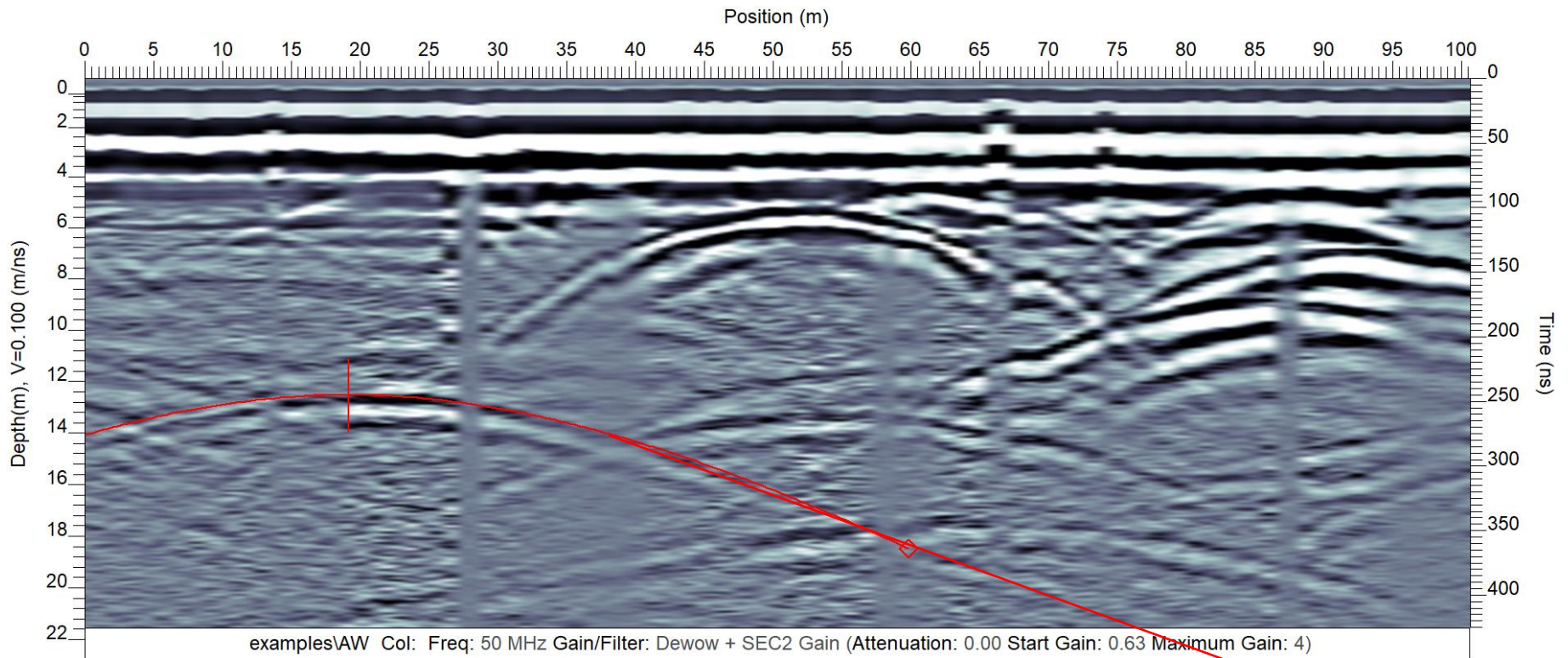

$V_1 = 0.3$ m/ns

Field example

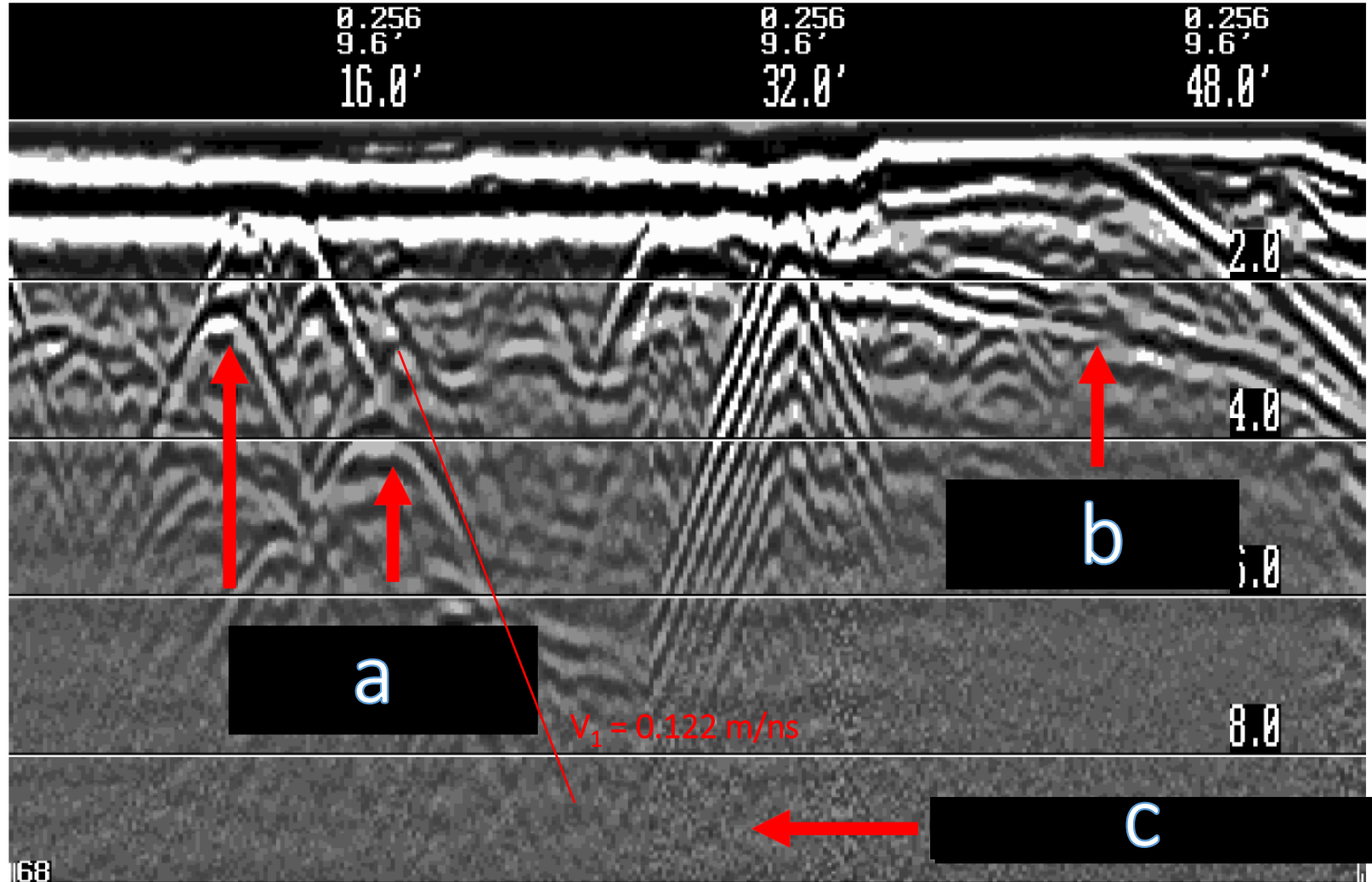

Field example

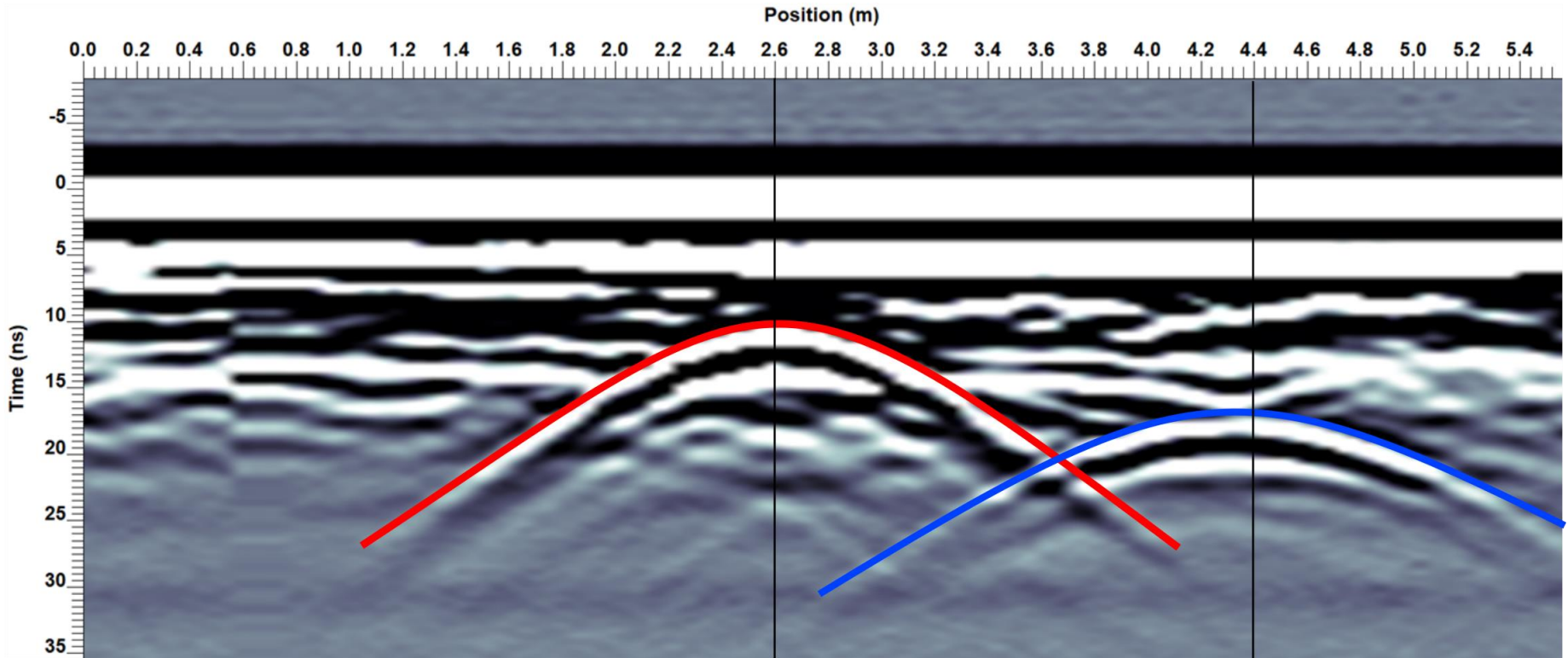

$V_1 = 0.108 \text{ m/ns}$; $t_0 = 10 \text{ ns}$; $x_0 = 2.6 \text{ m}$

$V_2 = 0.122 \text{ m/ns}$; $t_0 = 17 \text{ ns}$; $x_0 = 4.4 \text{ m}$